



GALVA COAT
INDUSTRIES

THE **QUALITY**, THE **MODERN**
THE **PROFESSIONALISM**

TABLE OF CONTENT

▶ About Galva Coat Industries	3
▶ History	5
▶ Mission & Vision	8
▶ Our Team	9
▶ Manufacturing Excellence	13
▶ Poles	15
▶ Guard Rails	21
▶ Hot Dip Galvanizing	27
▶ Engineering & Design	31
▶ Quality Control	33
▶ Quality Assurance	36
▶ Industrial Award	37
▶ Metal Work & Accessories	39
▶ Cable Tray Assembly	41
▶ Cable Ladder Assembly	55
▶ Cable Tray & Ladder Covers	67
▶ Cable Trunking Assembly	75
▶ Base Plates	87
▶ Cantilever Arms	88
▶ Hardware	89



The finest
STEEL
*has to go
through the*
HOTTEST FIRE

▶ ABOUT **GALVA** **COAT INDUSTRIES**

- Galva Coat Industries was established in 1995 in the industrial city of Abu Dhabi is one of the major manufacturing organizations not only in U.A.E but in the entire region.
- Due to the rigorous quality of our products and service, supported with sound strategies, GALVA COAT's position is strongly recognized in the UAE market as well as in the GCC Countries.
- During the last years GALVACOAT has obtained more and more marketplace and remarkable increase in its market share.

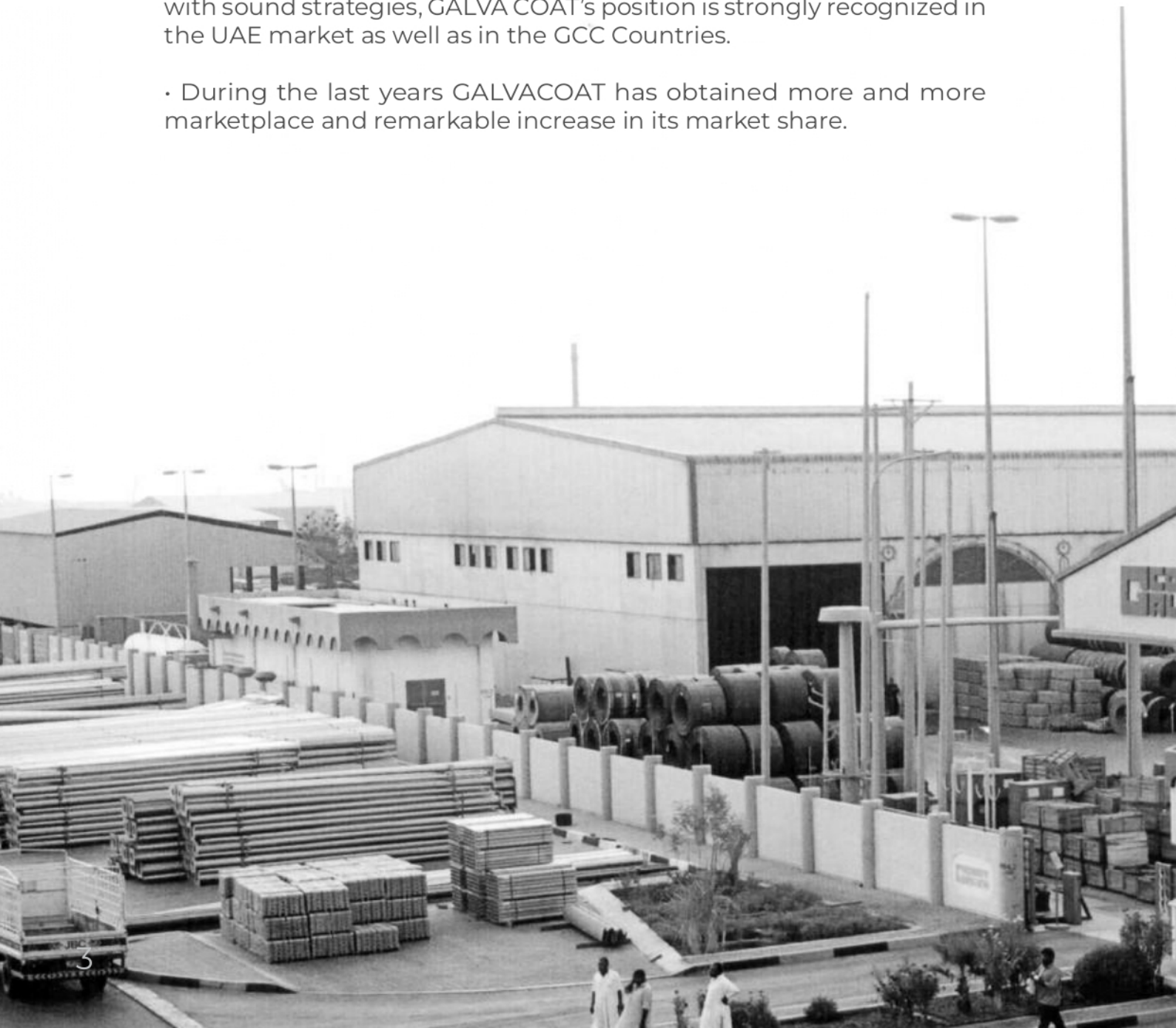

GALVA COAT began to meet the demands of the urban requirements and economic advancement in the United Arab Emirates in 1995 by the late Mr. Fatallah Abdulla Ikhdayer, who was inspired by the determination of His Highness Sheikh Zayed Bin Sultan Al Nahyan to develop our prosperous nation in a way no country had seen before.

Mr. Ikhdayer devoted his efforts to contribute to the development of the United Arab Emirates. He was successful in establishing several infrastructural companies in the UAE, including the following specialized companies:

1. Al Barrak Electrical Contracting Co, 1976
2. Copri Construction Enterprises Est., 1981
3. Al Sultan Industrial Cement, 1992
4. Galva Coat Industries, 1995
5. Al Barrak Crushers, 1997
6. Al Barrak General Transport, 1989



HISTORY

Since 1995, Galva Coat Industries has been operating as an Emirati National Organization.



Due to the rigorous quality of our products and services, Galva Coat Industries has received a remarkable increase in market shares and market place value, claiming more than 7,800 clients! We have exported our products to:

- Saudi Arabia
- Jordan
- Oman
- Kuwait
- Qatar
- Africa
- Bahrain
- India
- The United Kingdom (UK)

We are very proud to have been an integral part of the growth of the UAE, and now many other countries around the world; we will continue to do so with the same quality, passion, and determination as we have done to date.







Our Vision

Our VISION is to maintain and improve our position in the market as a leading supplier of galvanized steel products in the U.A.E. and the Middle East by providing our clients with the best quality products and services of the highest international standards.

Our Mission

- Provide safe and environmentally friendly working conditions.
- Protect the Environment throughout all our operations.
- Ensure business sustainability.
- Provide our Customers with a Complete Solution for their steel projects.
- Develop partnerships with key customers to become their preferred supplier of galvanized steel products.
- Supply quality products with enhanced service.
- Operate efficiently and become cost competitive.
- Develop the skills and engagement of our employees.

Our Values

- Safety First
- Quality
- Environment Protection
- Career Builders
- Trust
- Integrity

Our Team



In 2008, Mr. Islam Ikhdayer proudly joined our office as Managing Director of Galva Coat Industries and is an existing member of our Group since 2012. Mr. Islam believes that a company's workforce and ethical values are its most important assets. Under his leadership, our company has remained in a strong position in both local and regional markets. Mr. Islam is known for his ambition, as he is always striving to achieve excellence in all aspects of our business. He is passionate and qualified, allowing him to strengthen relationships and trust with our stakeholders. Mr. Islam's thoughts are inspired by the UAE Leader's Philosophy, that there is nothing impossible when it comes to achieving our objectives.

In addition to impeccable management, Galva Coat has committed itself to hiring the most talented candidate for each staff position.





Business Development Staff

Our sales department consists of a talented team of well-trained individuals, groomed to fulfil our customer's queries and requirements adequately.



Estimation Staff

Consists of highly competent engineers to ensure competitive pricing and reasonable costs against the quality of our products, to provide customers with more than what they pay for.



Customer Service Staff

Our Customer Services Team has been trained to attend to our customer's requirements and are always striving to increase our customer's satisfaction by addressing questions, queries, and any other needs.



Engineering & Design Staff

Galva Coat is proud to have invested in a highly talented design and engineering team. Each member has strong hands-on experience of designing various types of steel products.

Our Design Engineers are equipped with the most advanced software such as STAADPRO for Structural Design, custom-made spreadsheets for connections and TEKLA structures, and AutoCAD for structural steel detailing.



Materials Planning & Procurement Staff

This team specializes in planning and procuring the best quality of raw materials used in our steel products. They work endlessly to find the best quality items to ensure your satisfaction.



Purchase Staff

Galva Coat deals with suppliers via our certified procurement team and ensures that we are provided with supplies that comply with authority requirements to utilize green resources and ensure environmental protection.



HSE Staff

Galva Coat maintains a strict 'safety first' philosophy among all the operations in the factory, and we believe that our laborers are the most valuable asset for our business continuity. Each and every step in our operations is well evaluated to eliminate the risks and ensure the safety of our workers.



HR Staff

Our HR Staff are professionals and experienced in managing our human resources department. They strive to always have qualified and competent staff and workers in our operation, by implementing a well-organized training system.

► Manufacturing Excellence

We are equipped with the most modern manufacturing machineries from reputable European Companies with advanced technology comprising of but not limited to De-coilers, Shearing machines, Folding machines, Robotic welding machines, Guard Rail Machines, CNC Punch Machines, Laser Cutting Machines and Hot Dip galvanizing processes combined with state- of-the-art Enterprise Resource Planning (ERP) system tailored to this industry and well trained professional staff and the expertise to offer you:

- Street lighting poles, Decorative poles & Garden poles.
- High masts with fixed head frame & High masts with raising and lowering gear.
- Transmission masts for 11 & 33 KV.
- Communication Masts (Mono Poles – Etisalat Poles).
- Corrugated Double Wave Guard Rails (Crash Barriers), Beams, posts, spacers, and Guard Rails Accessories.
- Hot Dip Galvanizing process.
- Fabrication of Steel Structures.
- Cable Management System
- Cable Tray & Accessories
- Cable Ladder & Accessories
- Cable Trucking & Accessories
- C-Channel Fittings
- Laser Cutting Services of Flat bars/tubes, etc

“

The road to
SUCCESS
is always under
CONSTRUCTION

We are also proud to have one of the biggest FOLDING MACHINES in the world with the below mentioned capacity:

- * *Folding Length 15 meters.*
- * *Maximum thickness of 50 mm Steel Plates*
- * *Variable Punch, Die Setting & Bending*



▶ POLES

Galva Coat Industries manufacturing a wide range of steel products such as all types of street lighting poles, Power transmission poles, Steel Decorative Poles, and many steel structure works by using up-to-date technology CNC & PLC controlled machines, with minimum manual handling required using raw materials from first class European steel mills.



Galva Coat equipped with the most modern steel manufacturing machines such as 14-meter-long shear machine and 15-meter-long press brake for production of all types and length of poles such as Octagonal, Polygonal, and Conical Poles, and as a standard procedure, poles are delivered hot dip Galvanized.

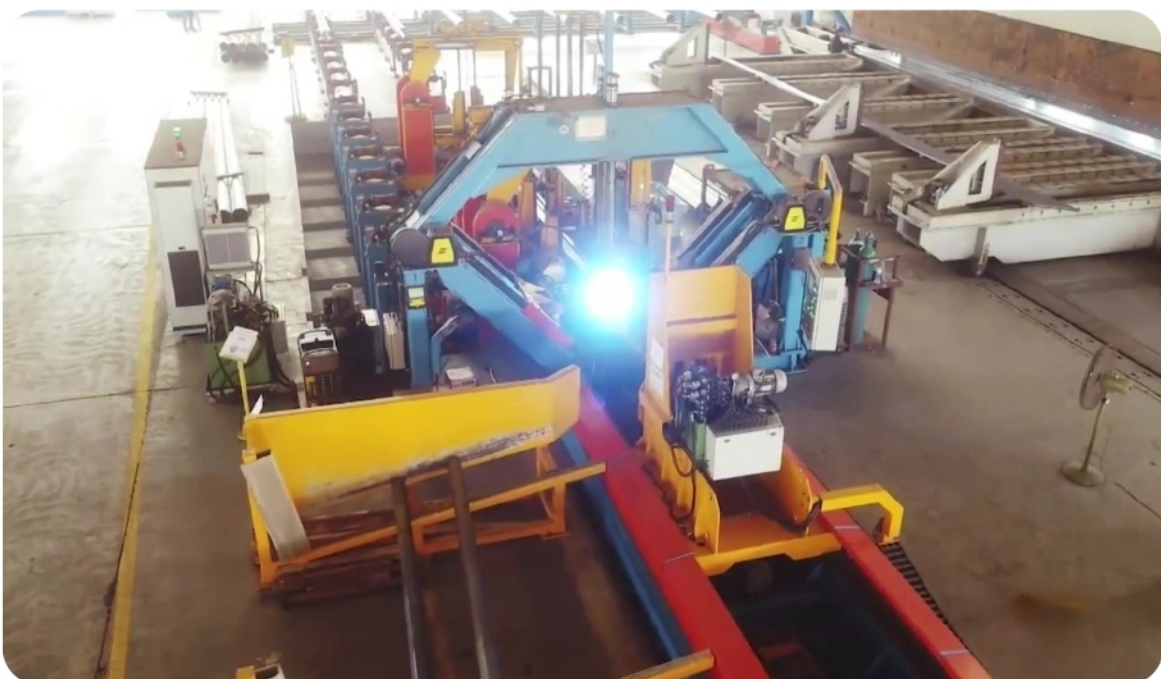



- **Octagonal Lighting Poles:**

Octagonal street lighting poles up to 14 meters height in one segment.

Octagonal street lighting poles up to any required length. (multi-segments).

Round conical street lighting poles up to 14 meters height.

▶ Traffic Signal Poles

Our sleek traffic signal poles are produced to meet authority requirements and standards and are optionally used for sign boards or traffic signs, with low maintenance as they are galvanized in house.

- Traffic Signal Poles as per local and international standards.



▶ Flag Poles

Galva Coat will enable you to raise your flag with pride, allowing it to fly to custom heights on the highest quality, galvanized, and paint coated poles.

- Decorative poles for urban use in streets, gardens, car park and private projects.



▶ **Camera Poles**

We have been fabricating quality security camera poles for leading companies and government entities. These poles can be manufactured in fixed or mid hinged, tapered poles, with required shape to suit the decorative architectural range.



Monopoles/Scada Mast & High Masts (with all necessary accessories)

▶ **Antenna Monopoles**

We can design and produce monopoles with any height to meet various transmission strength levels and support strong connection through wide ranges and areas. These Monopoles are usually used for telecommunication purposes.

- Monopoles are supplied with heights more than 40M to support transmission antennas.

▶ **Electric Transmission Monopoles**

Our electric transmission monopoles are popularly replacing lattice towers due to many advantages such as: less area of land required, prompt erection time, appealing shape, and low maintenance cost.

Steel transmission monopoles are used all over the world to carry Electrical Transmission lines up to 415 KV. They are used in many areas replacing Steel Towers (Lattice Towers) due to many advantages such as:



- Less area of land required
- Less and quick erection time
- Better shape
- Easy maintenance & less maintenance cost.



▶ **High Masts with R&L Gears:**

We have been fabricating quality high mast with raising and lowering gear system, these poles is a safe system due to reliable service hoist which raises and lowers the fixtures ring for maintenance purposes.

High Masts are designed & supplied with heights up to SOM and equipped with Raising and Lowering Gear system that is lowered and raised electrically for maintenance of Luminaries

▶ **Stadium Lighting High Masts**

Turn night into day for concerts and sporting events using our stadium lighting masts. These majestic poles are intentionally designed with a head frame needed to carry many flood lights, traditionally used in stadiums, parks, public arenas, etc. Our high Masts can also be equipped with protective wire mesh for safety purposes at any heights.

▶ **Hinged Poles**

With the concept of low investment for street lighting on highways, we offer hinged poles that can reach up to an impressive 30-meters in height. Hinged Poles can give our clients the advantage of low maintenance cost without blocking the highways and disturbing the traffic, as this type of pole can be lowered without any special lowering means. It is also considered as a desirable option for use under overhead lines, as well as critical areas.

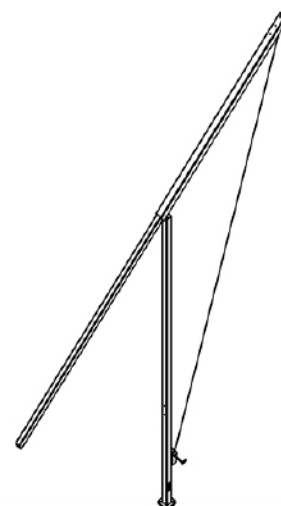

GUARD RAIL





Steel Guard Rails aiming at reducing considerably the risks caused by road accidents. Steel Guard Rails are used to prevent the vehicle from going out of the road with the least damage to the vehicle.

▶ **A- Beam Type Guard Rail**

Galva Coat is producing double corrugated guard rails, using the latest technique of continuous forming system. The corrugated safety rails or guard rails are the most widely specified type of guard rails to reduce road accidents.

Galva Coat manufacture guard rails including beams, posts, spacers, and all other related accessories using the most advanced technologies and under full quality control system. All produced parts of the guard rails are hot dip galvanized according to BS and ASTM standards.

The excellent quality of products, and the competitive prices, granted Galva Coat a good reputation not only in the local markets but also in the regional and middle east markets as well.

► Specifications

Galva Coat is producing guard rails with different beam center to center lengths varying from 3.00m c/c to 4.00m c/c.

Specifications of guard rail components are as follows

GALVA COAT STANDARD PRODUCTS												
TYPE	BEAM		POST				SPACER				BOLTS& NUTS	
	EL [mm]	AL [mm]	PH	PW	PT	PL	SH	SW	ST	SL		
GC 3200	3200	3516	150x75x5 mm			1200-2000 mm	150x75x5 mm				350	M 16 x 30 HDG
GC 3810	3810	4126									350	M 16 x 30 HDG
GC 4000	4000	4316									350	M 16 x 30 HDG

*** OTHER SIZES ARE ALSO AVAILABLE FOR 'BEAM & POST'**

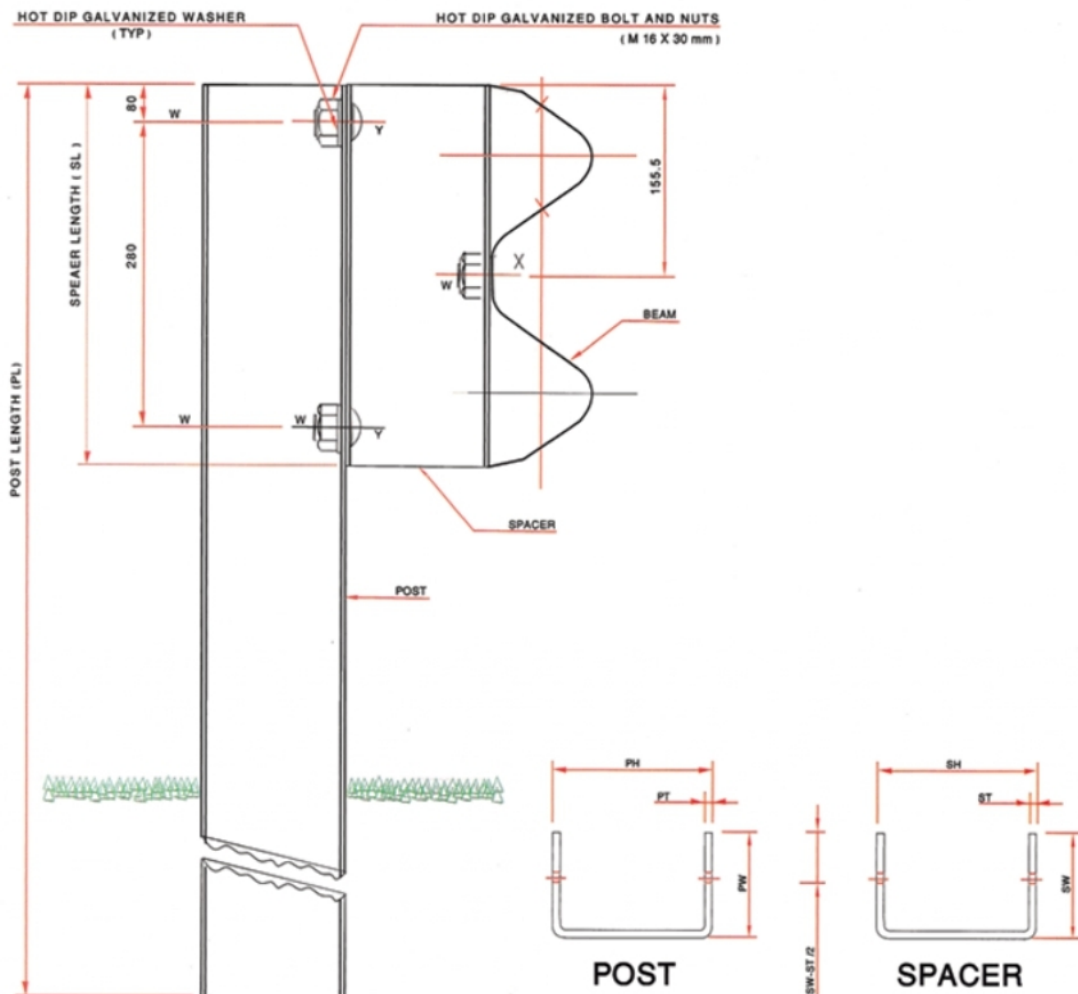

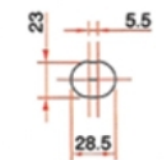
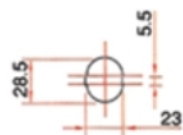
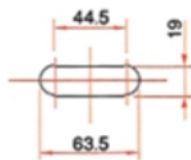
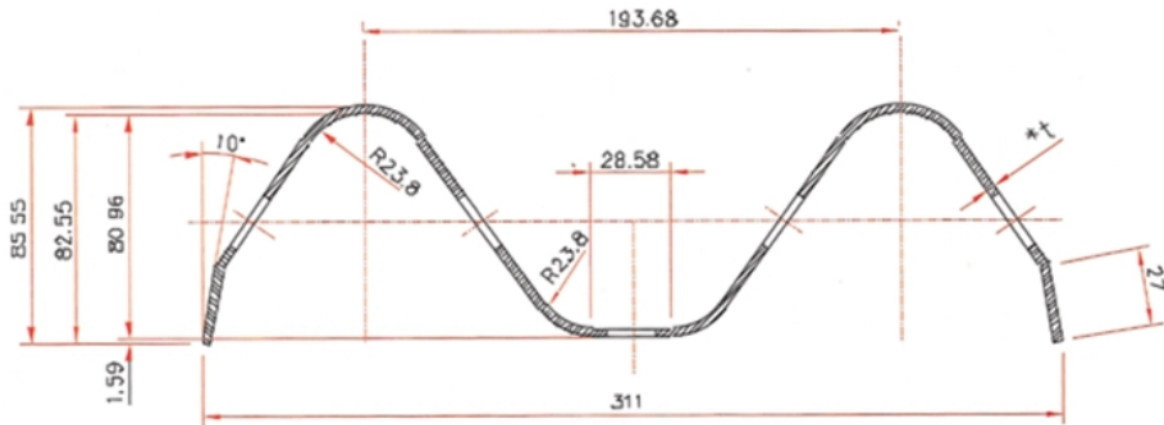

▶ **MATERIALS**

▶ **Beams**

Beams are manufactured from high quality hot rolled coils from European mills with any required steel grade and as per international standards: AASHTO M183, or AASHTO M180. Beams are automatically formed and punched using continuous forming and punching line. The sheet width of the beam is 480mm, thickness of sheet is variable from 2.7 mm, 2.75 mm and 3.43 mm or any other thickness required.

▶ **Fixing Bolts & Nuts**

All fixing bolts, nuts and washers are of grade 8.8 Hot Dip Galvanized to ASTM 153 and the name “Galva Coat” at the head of the bolt.

All parts of the guard rail such as beams, posts and spacers are hot dip galvanized according to ASTM A 123 and BS 72 9. Hot dip galvanizing is done in Galva Coat galvanizing plant.

▶ **Posts and Spacers**

Posts and spacers are made as well from top quality hot rolled coils formed to any required dimensions and thickness of using the same technique of cold forming process.

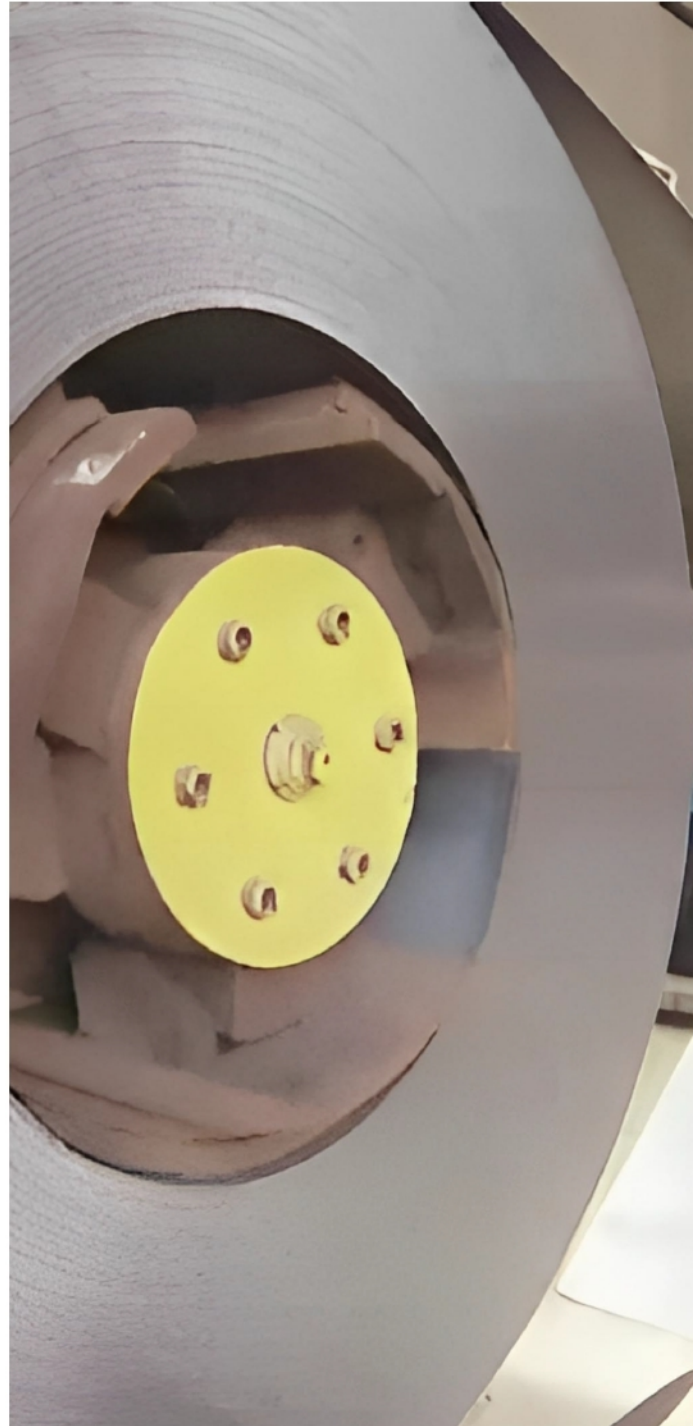

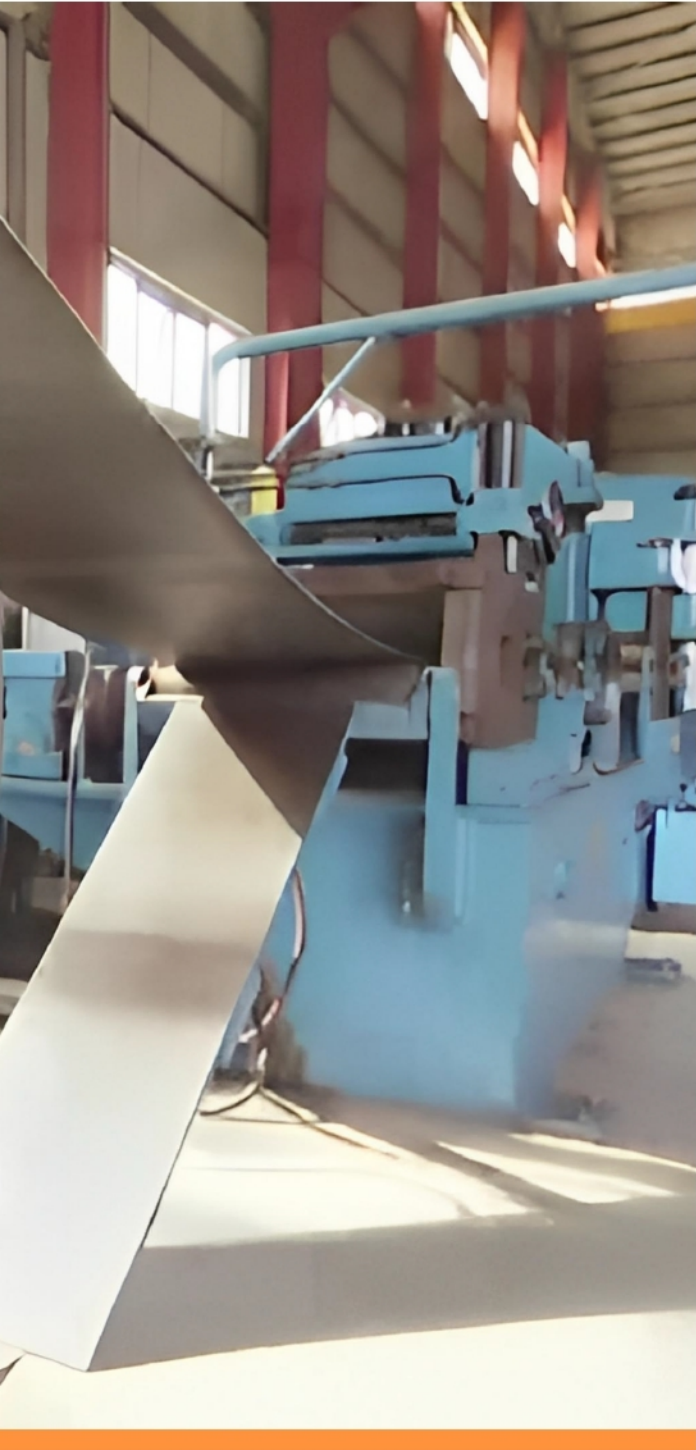

▶ B- Wire Rope Crash Barriers

Galva Coat can fabricate & supply wire rope crash barrier system which consists of the following:

- **Steel Wire Rope:** 19 mm dia wire rope can be supplied with 3 or 4 wires systems in each post. Hot dip galvanized.
- **Steel posts:** Made of channel 100x50x4 mm fabricated from steel grade 43 A to BS 4360 or equivalent. Hot dip galvanized.
- **Accessories:** Including end anchorage, bolts, reflectors, etc.





HOT DIP GALVANIZING

Galva Coat has one of the biggest galvanizing plants in the Middle East with Zinc kettle dimension of 15.5m length, 2.2m width and 3m depth.

Galva Coat is well equipped with laboratories for testing and maintaining the quality to assure that our products are coming out with zero errors.

Corrosion prevention is an essential factor in the economic utilization of the steel. In most steel products hot dip galvanizing provides ideal corrosion protection for steel. No other protective coating matches galvanizing unique combination of low first cost, ease of inspection for coating quality, durability, predictable performance low maintenance, and resistance to impacts and mechanical damage.



Galvanizing provides abrasion resistant coating for an exceptionally longer period. No other protective coating can match this unique process.

Since galvanizing involves coating of zinc with base steel at a considerably low cost and relatively high negligible maintenance for a longer duration, it is considered to be the most cost-effective coating today.

The galvanized coating becomes part of the steel surface as it forms zinc-iron alloy layers and metallurgic ally bonds to the base steel.

The corrosion rate is extremely slow compared to other conventional coatings. The mechanical properties of commonly galvanized steel are not affected by galvanizing

► Galvanizing Procedure:

Steel materials to be galvanized pass through the following procedures:

- 1- Degreasing:** Where the material is immersed into degreasing path to remove grease, paint, and oil from the surface.
- 2- Rinsing:** Rinsing with water to remove degreasing materials.
- 3- Picking:** The steel materials are immersed into HCL solution tank for approximately 1 to 2 hours to remove all rust from steel surface.
- 4- Rinsing:** Rinsing with water one more time to rinse the HCL.
- 5- Fluxing:** The clean steel is immersed in a flux tank consisting of zinc ammonium chloride solution to wet the steel surface and prevent oxidation before galvanizing process.
- 6- Drying:** The steel material is then placed in a hot air oven to dry the flux and make a thin film of flux over the steel surface.
- 7- Dipping in Molten Zinc:** This is the most important step: the steel material is dipped in molten zinc bath at a temp. of 450-degree C. for a measured time to form the required zinc iron alloy thickness that varies depending on the steel material specifications.
- 8- Quenching:** The galvanized materials are either air cooled or quenched into water bath
- 9- Passivity:** The galvanized materials are dipped in the passivity tank whenever required to prevent wet storage stains or white rust.



All galvanized products are packed and bundled with wooden spacers before delivery to customers



▶ **ENGINEERING & DESIGN**

Galva Coat has invested tremendously in sophisticated special design program to design the most economical poles.

Each project is designed according to American and British standards taking into consideration all related parameters such as wind speed, height, and type of luminaries.

Our Design Engineers with their experience in this industry, in conjunction with the latest specialized software packages available, are designing Poles/ Masts and Steel Structures to give optimum performance, in line with international standards. We have an excellent blend of experienced Engineers heading the various manufacturing and supporting functions.



QUALITY CONTROL

Quality is one of the most important functions and performance from the early begin- nine stages starting from preparing the offer to customer and ending with delivery.

Step by step checking is made in order to control material and production to be in accordance with the specifications and in line with international standards and tolerances.

Galva Coat has a big team of Quality Control Engineers and Inspectors.

Galva Coat is maintaining a Quality Control Department with latest and updated Instruments to monitor each stage and process, starting from receiving of material, until dispatch, thus maintaining quality throughout the execution of the job.







▶ **QUALITY ASSURANCE**

Galva Coat is committed to achieve utmost Customer satisfaction by producing consistent High-quality products that meet customer requirements and adherence to all statutory and regulatory requirements, as applicable.

Galva Coat also equally committed to adopt a pro-active approach to protect its surroundings and environment, by minimizing the level of harmful emissions wherever it's practicable and Dispose of the waste and effluents in a safe way, in line with the regulation to prevent pollution of land, water and air by exercising proper control over its activities and operations.

As an outcome of our hard work, Galva Coat been successful in obtaining ISO 9001 (Quality Management System) as well as ISO 14001 (Environmental Management System) Certification. Galva Coat is an affiliate member of Galvanizers Association-U.K.

Apart from the above Galva Coat is also in the process of achieving EHSMS (Environment, Health & Safety Management System) in line with Abu Dhabi Zones Corp Regulatory framework (OSHAD).

INDUSTRIAL AWARD

As an outcome of our hard work and outstanding performance against the criteria in the Manufacturing Industry we have been successful in winning the **“Sheikh Khalifa Industry GOLDEN Award”** three times - in **1999, 2001 & 2003**, in addition to the **“Special Environment Award”**, as a recognition of our great role in maintaining a sound and safety industrial working and surrounding environment.



Sheikh Khalifa Industry Golden Award (1999)



Sheikh Khalifa Environment Award (1999)



Galvanizing & Lighting Poles Award

Apart from the above, in appreciation of the persistent distinguished efforts and commitment to Quality as an ideal approach towards achieving Business Excellence Galva coat was conferred with **QUALITY APPRECIATION CERTIFICATE** in the 12th cycle of **Sheikh Khalifa Excellence Award 2013**.

Galva Coat always believe that the main ingredient of success is the Rigorous Quality of products, the reasonable price, and the satisfaction of clients, supported by a well-structured organization having sound strategies always developing the awareness of the need and the expectation of the varies customers.



Sheikh Khalifa Industry Golden Award (2001 - 2002)



Sheikh Khalifa Industry Golden Award (2003)

METAL WORK & ACCESSORIES

Cable Tray Systems

Galva Coat is proud to offer high quality Cable Tray Systems that are a cost effective and reliable solution to cable installation work. In addition to the standard dimensions listed in the catalogue, Galva Coat can provide any other special dimension or design upon request.

Cable trays are standardly produced with perforation and return flange type. This design results in a perforated area for cables and an increased load capacity, while maintaining low weight of structure, and further couple high quality with low cost.

All products are tested, and the quality of our materials comply with British and International Standards.

In addition, Galva Coat provides:

- Cable Management System
- Cable Tray & Accessories
- Cable Ladder & Accessories
- Cable Truck & Accessories
- C-Channel Fittings



Galva Coat is equipped with the most modern machines to produce the above products, such as the following machines:

- *Laser Machine for decoration works and cutting Flat bars, Sheet, Tubes, etc.*
- *Punching Machine*
- *Bending Machine*
- *Shearing Machine*



CABLE TRAY ASSEMBLY

Cable Tray Assembly

- Cable Tray
- Horizontal 90° Bend
- Horizontal 45° Bend
- Horizontal Tee
- Horizontal Cross
- Outside Riser 90°
- Reducer Straight
- Reducer Right
- Reducer Left
- Vertical Adjustable Bend
- WYE Branch
- Straight Connector
- Straight Divider
- End Plate
- Cover

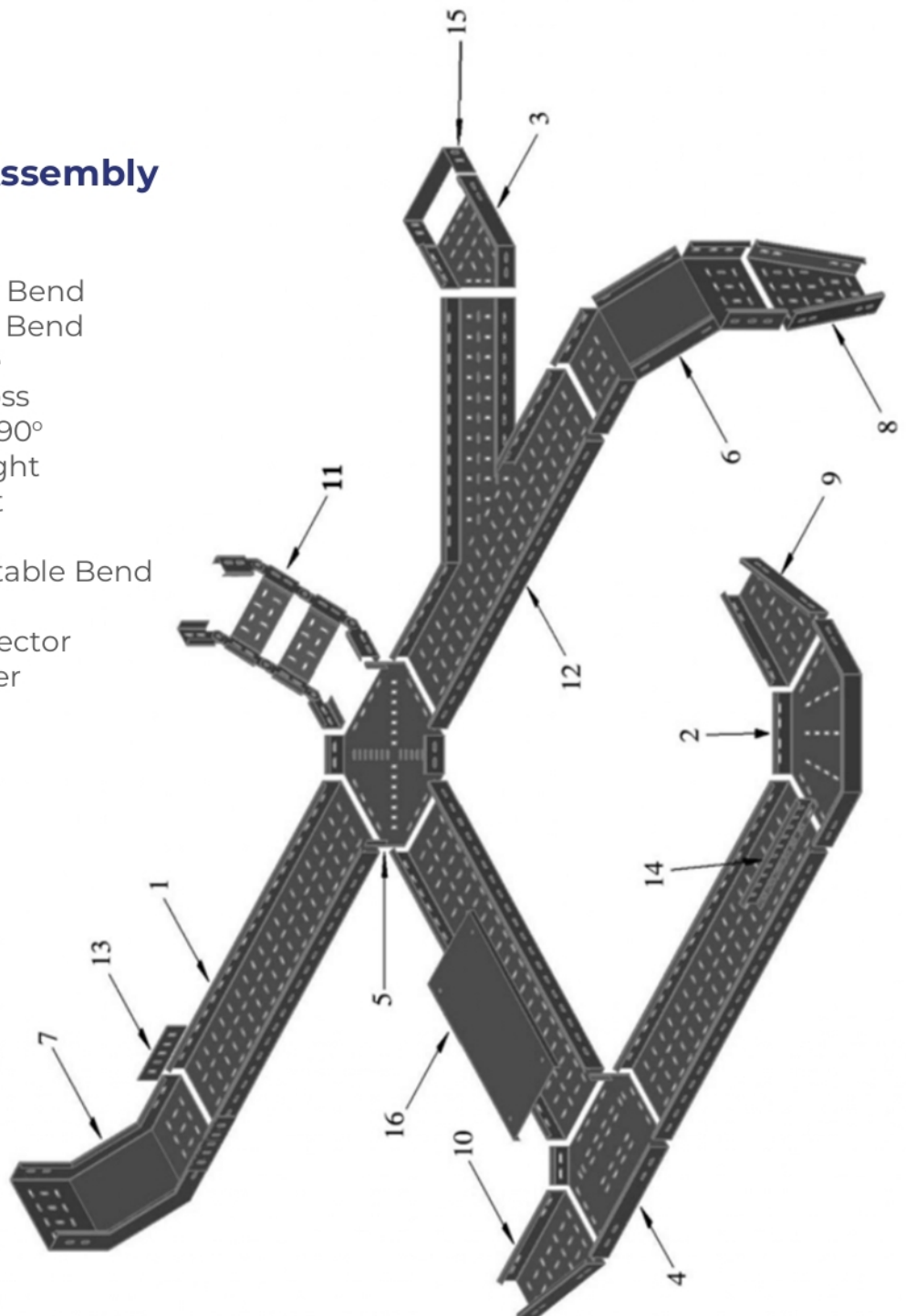

▶ **Hot-rolled mild steel grade DD11 to BS EN 10111:2008 (Mild Steel)**

(Formerly HR4 to BS 1449 Part 1)
DD11 hot-rolled mild steel is a cold forming material used for bending and drawing applications. This material is suitable for welding and hot dip galvanizing.

▶ **Cold-rolled mild steel grade DC01 to BS EN 10130:2006 (Mild Steel)**

(Formerly CR4 to BS 1449 Part 1)
DC01 cold-rolled steel grade is a cold-forming material for forming and deep drawing applications. This material is suitable for welding and hot dip galvanizing.

▶ **Pre-Galvanized Steel to BS EN 10346:2009 (G.I)**

(Formerly BS EN 10142:1991)
Hot dip galvanized (before manufacturing)
Continuously hot dip coated strip & sheet of low carbon steels for cold forming.

▶ **Stainless steel Marine grade 1.4404 to BS EN 10088-2: 2005**

(Formerly marine grade 316 to BS 1449 Part 2)
Marine grade 1.4404 stainless steel is a corrosion resistant Steel suited for coastal and offshore applications.

▶ **Stainless steel non-marine grade 1.4301 to BS EN 10088-2: 2005**

(Formerly grade 304 to BS 1449 Part 2).
The non-marine grade 1.4301 stainless steel used extensively in the food and processing industries.

▶ **Aluminium**

To ASTM B 209 M

The following is a list of manufacturing standards relating to cable management Systems:

BS EN ISO 1461 Hot dip galvanized coating on fabricated iron & steel formerly 729).

BS EN 10025-2:2004 Hot rolled products of structural steels. (Formerly BS EN10025:1993).

BS EN 10088-2:2005 Stainless steels for sheet/plate and strip for general purposes (formerly BS 1449Part 2).

BS EN 10111:2008 Continuously hot rolled low carbon steel sheet & strip for cold forming.

BS EN 10130:2000 Cold rolled low carbon flat products for cold forming.

BS EN 10136:2004 (formerly BS EN 10147:2000 & BS 2989)

BS EN 10326:2009 Continuously hot dip coated strip and sheet of structural steels.

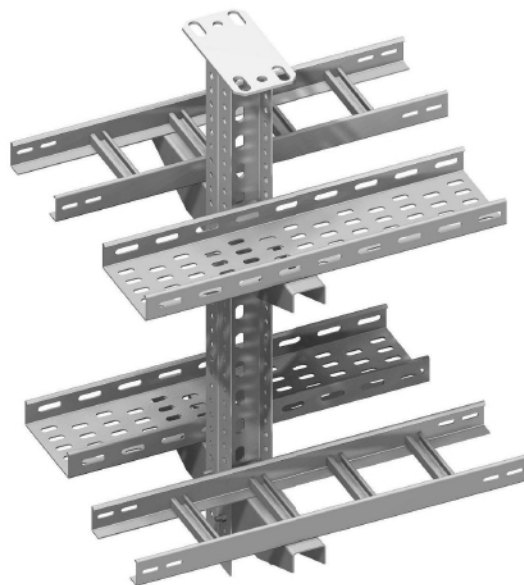



BS EN ISO 14713:1999 Protection against corrosion of iron and steel in structures – Zinc and aluminium coatings.

BS EN 10327:2004 Continuously hot dip coated strip & Sheet of low carbon steels for cold forming.

BS EN 50085-1:2005 Cable Trunking and cable ducting systems for electrical installations. (Formerly BS 4678 Part 1).

BS EN 61537:2007 Cable tray systems & cable ladder systems for cable management.

BS EN 10346:2009 Continuously hot dip coated strip & Sheet of low carbon steels for cold forming.

BS 6946:1988 Specification for metal channel cable support systems for electrical installations.

NEMA VE 1-2009 Metal Cable Tray Systems (also CSA International C22.2 No 126.1-98).

NEMA VE 2-2006 Cable Tray Installation Guidelines.

▶ ORDERING GUIDE

Cable Tray Straight (Perforated Type) - CT



Cable Tray Filling (Perforated Type) - CT

HG	Material Finish
CT	Material Type
TR	Tray Type
TH9B	Tray Filling Type
150	Tray Width
50	Tray Side Height
1.5	Tray Thickness



ORDERING INFORMATION

Material Finish	Tray Type	Tray Width	Side Height	Material Thickness	Length
HG- Hot Dip Galvanized after fabrication (HDGAF) to BS ISO EN 1461 (BS 729)	TR- Return Flange	2 in - 50 mm	1 in - 25 mm	1.0 mm	2440 mm
GI- Pre-Galvanized steel (Mill Finish) to BS EN 10346:2009 (BS EN 10142 & BS 2989)	TP- Plain Type	3 in - 75 mm	2 in - 50 mm	1.2 mm	3000 mm
AL- Aluminium (Mill Finish)	TO- Outside 90deg Flange	4 in - 100 mm	3 in - 75 mm	1.5 mm	
S6- Stainless Steel 316 (Mill Finish)	TI- Inside 90deg Flange	6 in - 150 mm	4 in - 100 mm	2.0 mm	
S4- Stainless Steel 304 (Mill Finish)		9 in - 225 mm			
		12 in - 300 mm			
		18 in - 450 mm			
		24 in - 600 mm			
		30 in - 750 mm			
		36 in - 900 mm			





CABLE TRAY STRAIGHT

Galva Coat Cable Tray systems provides high quality, cost effective and reliable solution to cable installation work. Perforated Cable Tray without flange or with flange inside and outside flange are available in 2.44 /3 meters. In addition to standard dimension listed in the catalogue “Galva Coat” can provide any other special dimension or design on request.

As standard production, cable trays are perforated with return flange type. This design result is a perforated area for cable and increased load capacity while maintaining low weight of structure in high quality with low coat.

All Products are tested, and quality of materials comply to British Standard & International Standards.

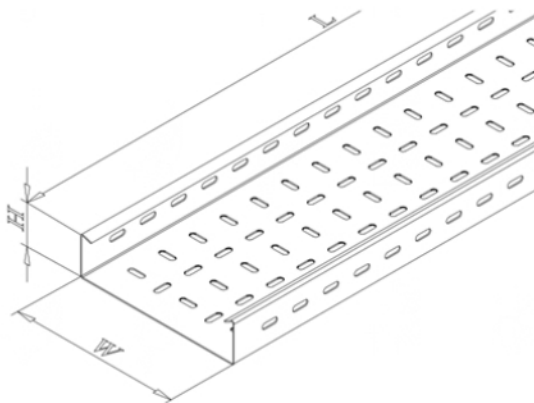

TR- Return Flange

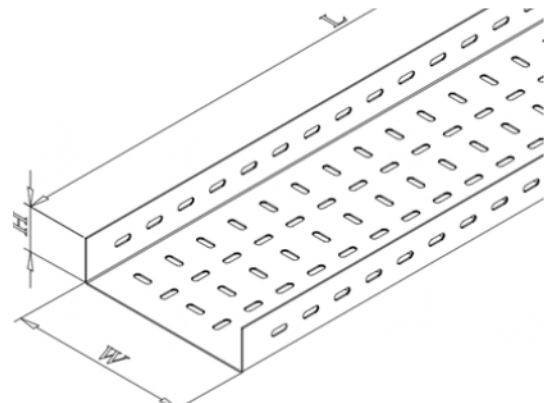

TP- Plain Type

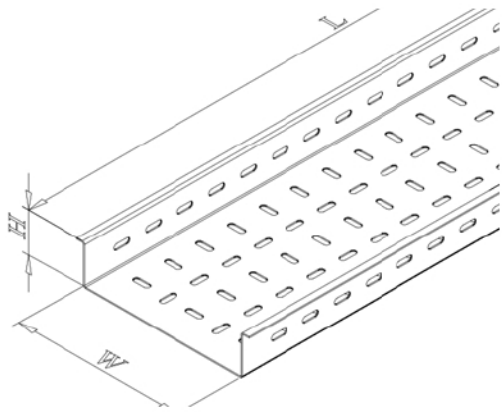

TO- Outside 90° Flange

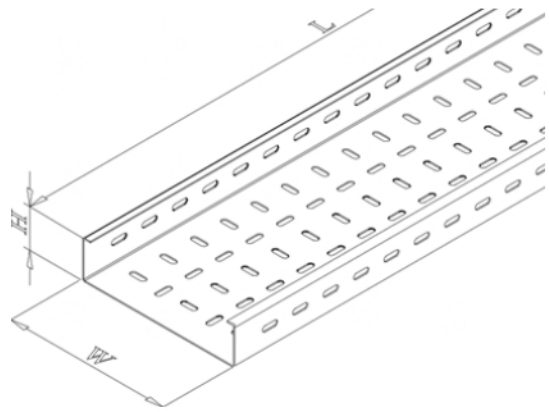

TI- Inside 90° Edge Type

Finish	Reference	Width	Heigh	Thickness	Length
HG/GI/AL/S4/S6	TR/TP/TO/TI	50	25/50	1.2/1.5/2.0mm	2440/3000mm
HG/GI/AL/S4/S6	TR/TP/TO/TI	75	25/50/75	1.2/1.5/2.0mm	2440/3000mm
HG/GI/AL/S4/S6	TR/TP/TO/TI	100	25/50/75/100	1.2/1.5/2.0mm	2440/3000mm
HG/GI/AL/S4/S6	TR/TP/TO/TI	150	25/50/75/100	1.2/1.5/2.0mm	2440/3000mm
HG/GI/AL/S4/S6	TR/TP/TO/TI	225	25/50/75/100	1.2/1.5/2.0mm	2440/3000mm
HG/GI/AL/S4/S6	TR/TP/TO/TI	300	25/50/75/100	1.2/1.5/2.0mm	2440/3000mm
HG/GI/AL/S4/S6	TR/TP/TO/TI	450	25/50/75/100	1.5/2.0mm	2440/3000mm
HG/GI/AL/S4/S6	TR/TP/TO/TI	600	25/50/75/100	1.5/2.0mm	2440/3000mm
HG/GI/AL/S4/S6	TR/TP/TO/TI	750	25/50/75/100	1.5/2.0mm	2440/3000mm
HG/GI/AL/S4/S6	TR/TP/TO/TI	900	25/50/75/100	1.5/2.0mm	2440/3000mm

***Cable Trays, of Other Width, Height, Thickness and Length are also available upon request**



CABLE TRAY FITTINGS

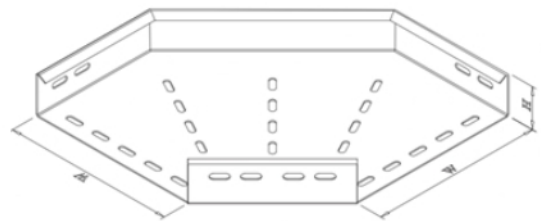

TH9B- Horizontal 90° Bend

Finish/TH9B/Width/ Height/ Thickness

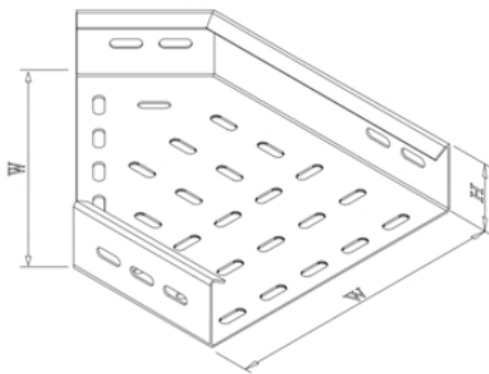

TH4B- Horizontal 45° Bend

Finish/TH4B/Width/ Height/ Thickness

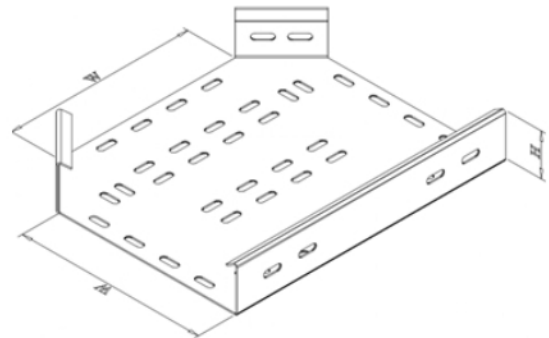

THT- Horizontal Tee

Finish/THT/Width/ Height/ Thickness

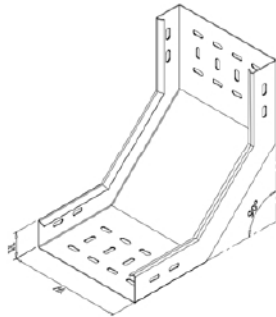

TIR- Inside Riser 90°
Finish/TIR/Width/ Height/ Thickness

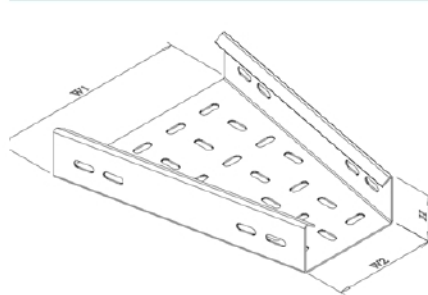

TRS- Reducer Straight
Finish/TRS/Width/ Height/ Thickness

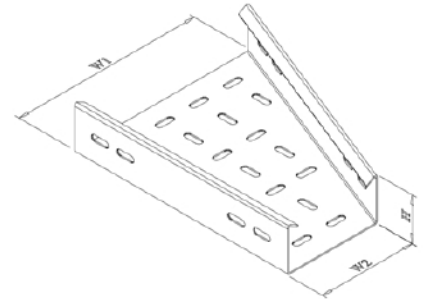

TRR- Reducer Right
Finish/TRR/Width/ Height/ Thickness

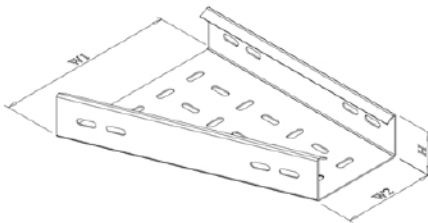

TRL- Reducer Left
Finish/TRL/Width/ Height/ Thickness

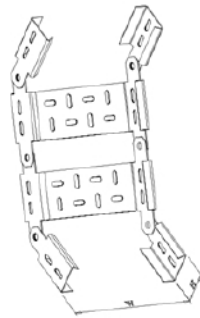

TVAB- Vertical Adjustable Bend
Finish/TVAB/Width/ Height/ Thickness

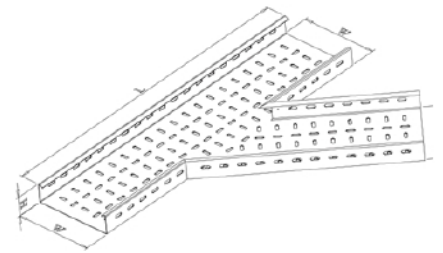

TY4B- WYE 45° Branch
Finish/TY4B/Width/ Height/ Thickness

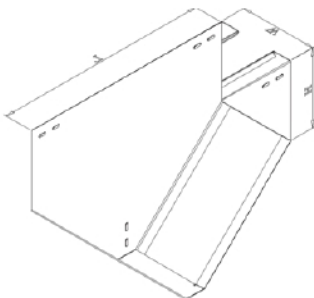

TV9T- Vertical 90° Tee
Finish/TV9T/Width/ Height/ Thickness

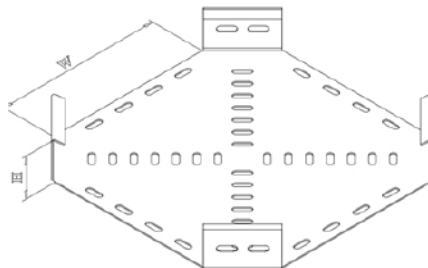

THC- Horizontal Cross
Finish/THC/Width/ Height/ Thickness

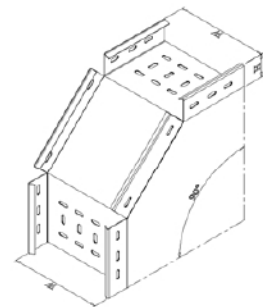

TOR- Outside Riser 90°
Finish/TOR/Width/ Height/ Thickness

CABLE TRAY ACCESSORIES

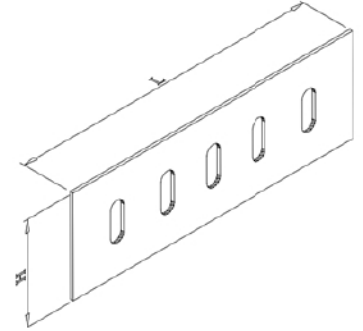

TA-101 Straight Connector

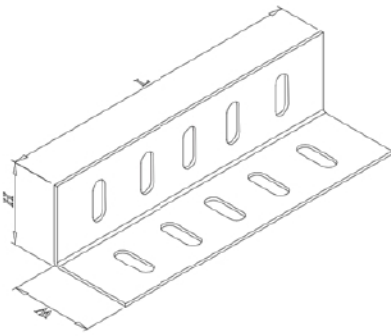

TA-102 Angle Connector

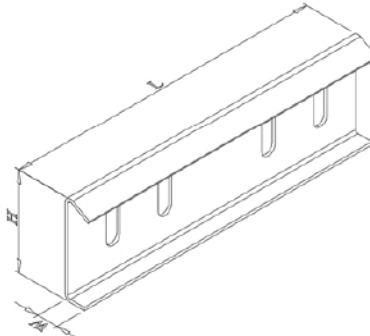

TA-103 Wrapover Connector

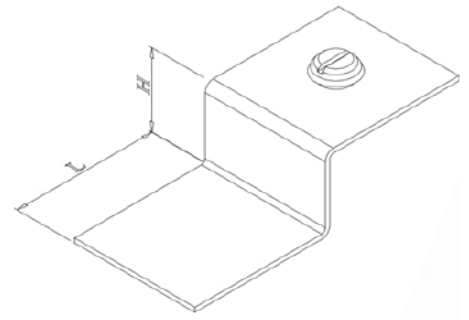

TA-116 Clover Clip

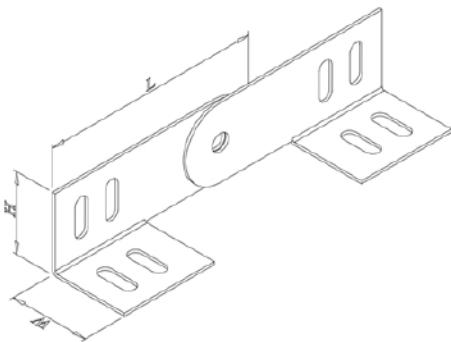

TA-104 Vertical Adjustable Connector

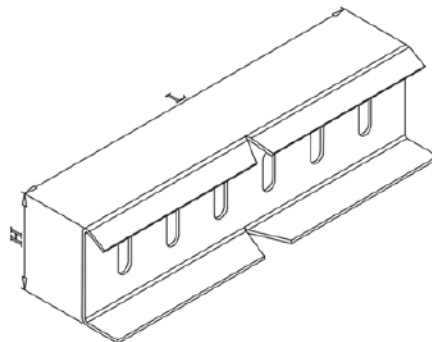

TA-105 Horizontal Adjustable Connector

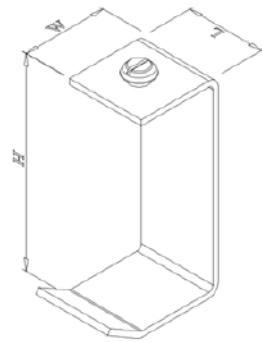

TA-115 Clover Clamp With Screw

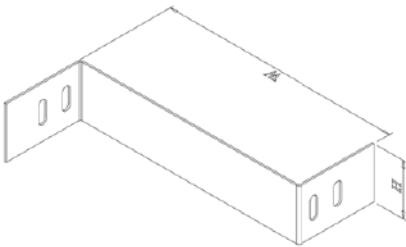

TA- 106 Reducing Connector

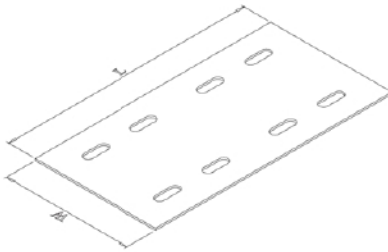

TA- 107 Fish Plate

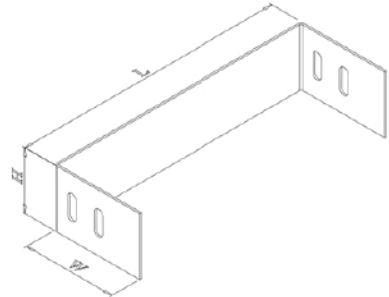

TA- 108 End Plate

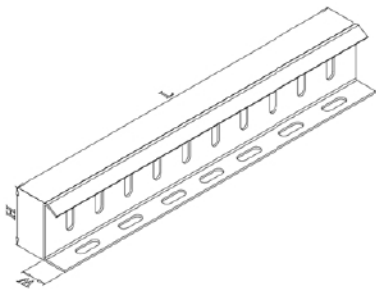

TA- 109 Straight Divider



TA- 110 Hold Down Bracket

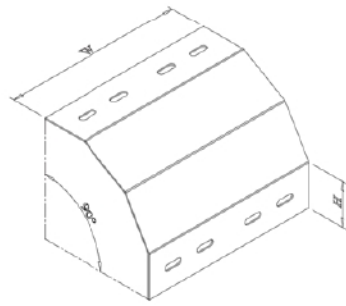

TA- 111 Drop Out



TA- 112 Earth Link

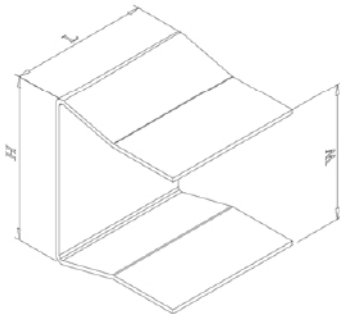

TA- 113 Cover Clamp

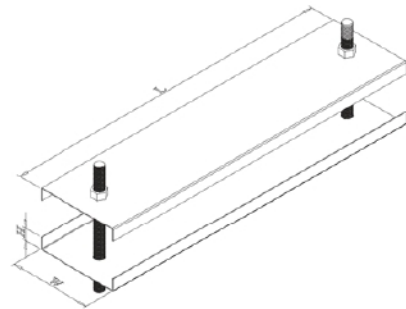

TA- 114 Double Cover Clamp



CABLE LADDER ASSEMBLY



Cable Ladder Assembly

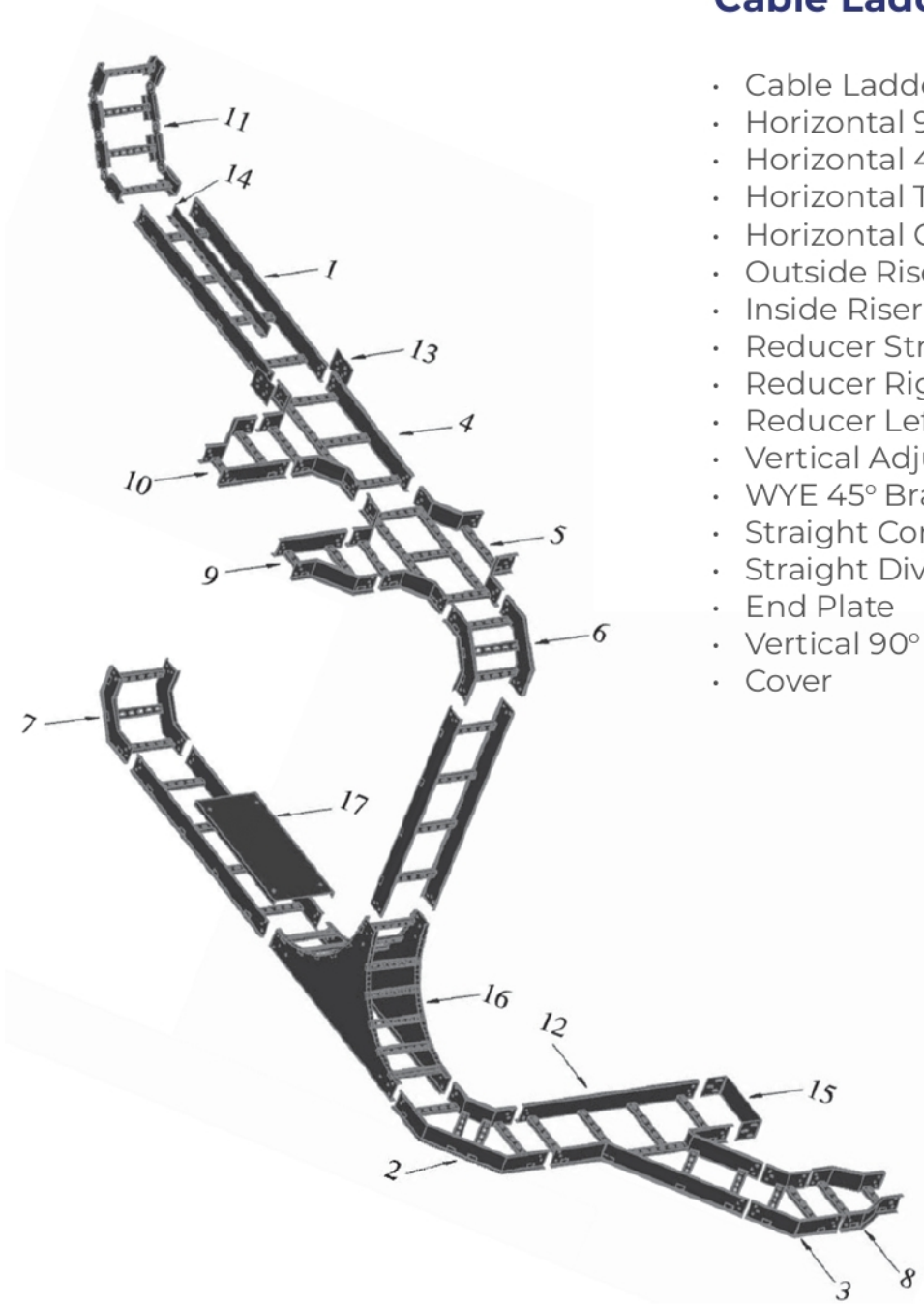

- Cable Ladder
- Horizontal 90° Bend
- Horizontal 45° Bend
- Horizontal Tee
- Horizontal Cross
- Outside Riser 90°
- Inside Riser 90°
- Reducer Straight
- Reducer Right
- Reducer Left
- Vertical Adjustable Bend
- WYE 45° Branch
- Straight Connector
- Straight Divider
- End Plate
- Vertical 90° Tee
- Cover

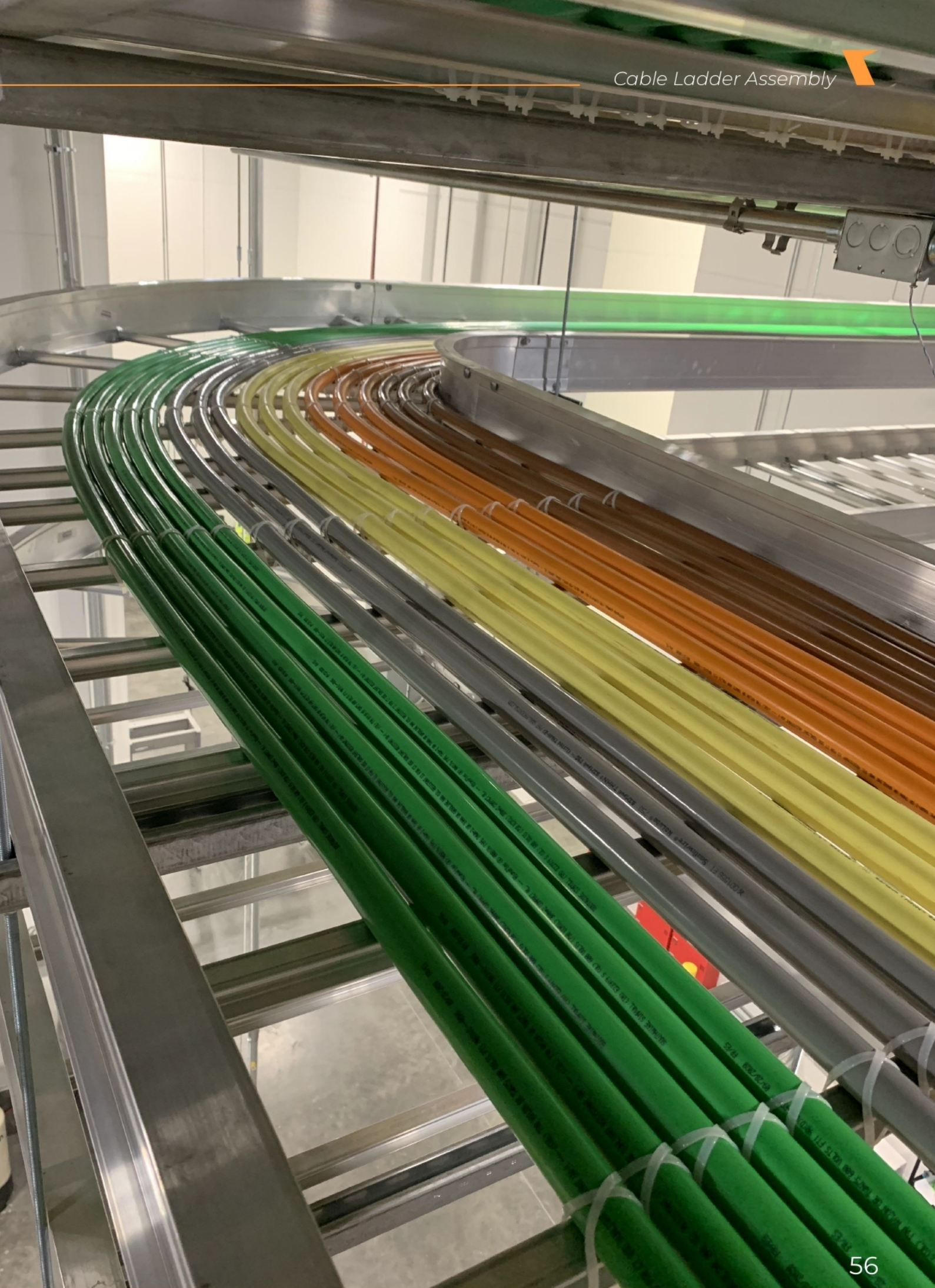

▶ ORDERING GUIDE

Cable Tray Straight (Weltded Type) - CL

HG	Material Finish
CL	Material Type
LO	Ladder Type
300	Ladder Width
100	Ladder Height
2	Ladder Thickness
3000	Ladder Length

Cable Tray Filling (Welded Type) - CL

HG	Material Finish
CL	Material Type
LO	Ladder Type
LH9B	Filling Type
300	Ladder Width
100	Ladder Height
2	Ladder Thickness



ORDERING INFORMATION

Material Finish	Ladder Type	Ladder Width	Side Height	Material Thickness	Length
HG- Hot Dip Galvanized after fabrication (HDGAF) to BS ISO EN 1461 (BS 729)	LI- Inside Flange	2 in - 50 mm	1 in - 25 mm	1.2 mm	2440 mm
GI- Pre-Galvanized steel (Mill Finish) to BS EN 10346:2009 (BS EN 10142 & BS 2989)	LO- Outside Flange	3 in - 75 mm	2 in - 50 mm	1.5 mm	3000 mm
AL- Aluminium (Mill Finish)	LE- Edge Outside Flange	4 in - 100 mm	3 in - 75 mm	2.0 mm	
S6- Stainless Steel 316 (Mill Finish)	LZ- Z Type Flange	6 in - 150 mm	4 in - 100 mm	2.5 mm	
S4- Stainless Steel 304 (Mill Finish)		9 in - 225 mm			
		12 in - 300 mm			
		18 in - 450 mm			
		24 in - 600 mm			
		30 in - 750 mm			
		36 in - 900 mm			





CABLE LADDER STRAIGHT

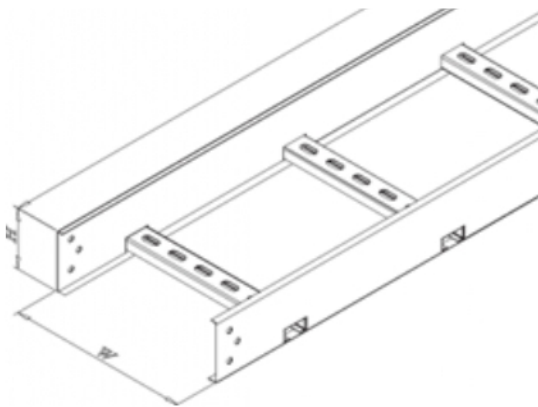

LI- Inside Flange

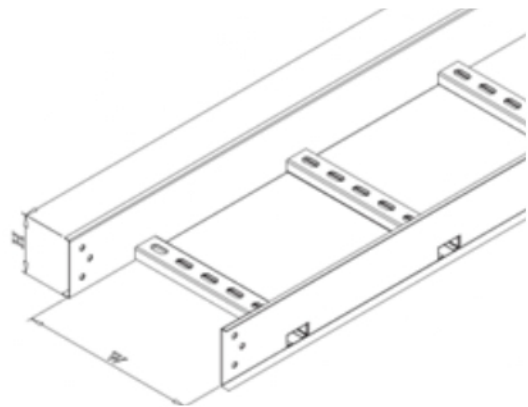

LO- Outside Flange

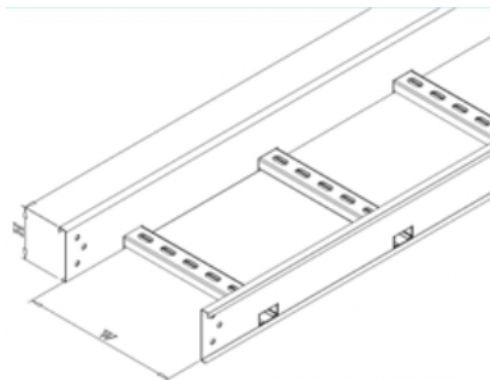

LE- Edge Outside Flange

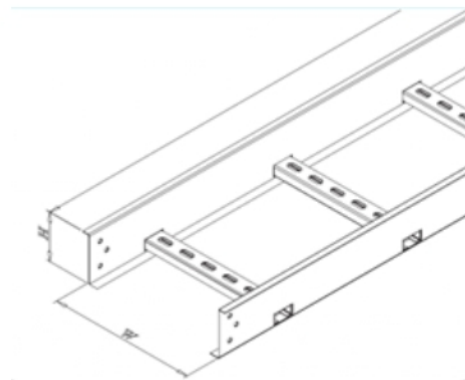

LZ- Z Type Flange



Finish	Reference	Width	Heigh	Thickness	Length
HG/GI/AL/S4/S6	LI/LO/LE/LZ	75	75/100/125/150	1.5/2.0mm	2440/3000mm
HG/GI/AL/S4/S6	LI/LO/LE/LZ	100	75/100/125/150	1.5/2.0mm	2440/3000mm
HG/GI/AL/S4/S6	LI/LO/LE/LZ	150	75/100/125/150	1.5/2.0mm	2440/3000mm
HG/GI/AL/S4/S6	LI/LO/LE/LZ	225	75/100/125/150	1.5/2.0mm	2440/3000mm
HG/GI/AL/S4/S6	LI/LO/LE/LZ	300	75/100/125/150	1.5/2.0mm	2440/3000mm
HG/GI/AL/S4/S6	LI/LO/LE/LZ	450	75/100/125/150	1.5/2.0mm	2440/3000mm
HG/GI/AL/S4/S6	LI/LO/LE/LZ	600	75/100/125/150	1.5/2.0mm	2440/3000mm
HG/GI/AL/S4/S6	LI/LO/LE/LZ	750	75/100/125/150	1.5/2.0mm	2440/3000mm
HG/GI/AL/S4/S6	LI/LO/LE/LZ	900	75/100/125/150	1.5/2.0mm	2440/3000mm
HG/GI/AL/S4/S6	LI/LO/LE/LZ	1000	75/100/125/150	1.5/2.0mm	2440/3000mm



CABLE LADDER FITTINGS

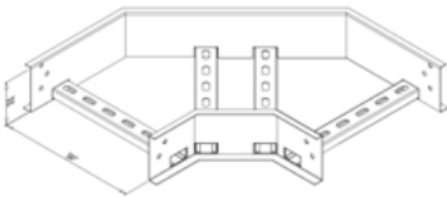

LH9B- Horizontal 90° Bend
Finish/LH9B/Width/ Height/ Thickness

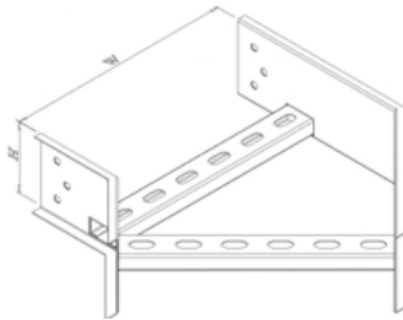

LH4B- Horizontal 45° Bend
Finish/LH4B/Width/ Height/ Thickness

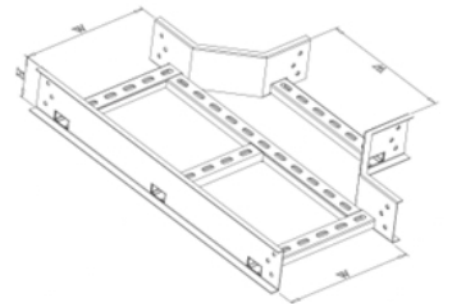

LHT- Horizontal Tee
Finish/LHT/Width/ Height/ Thickness

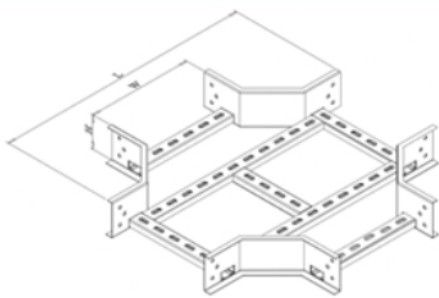

LHC- Horizontal Cross
Finish/LHC/Width/ Height/ Thickness

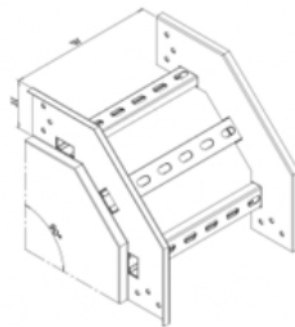

LOR- Outside Riser 90°
Finish/LOR/Width/ Height/ Thickness

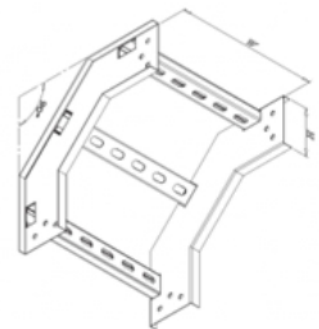

LIR- Inside Riser 90°
Finish/LIR/Width/ Height/ Thickness

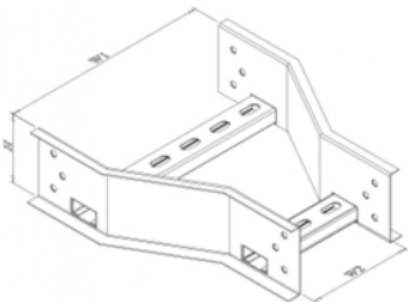

LRS- Reducer Straight
Finish/LRS/Width/ Height/ Thickness

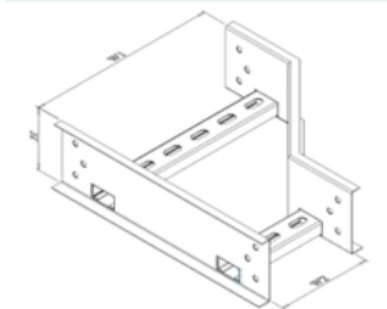

LRR- Reducer Right
Finish/LRR/Width/ Height/ Thickness

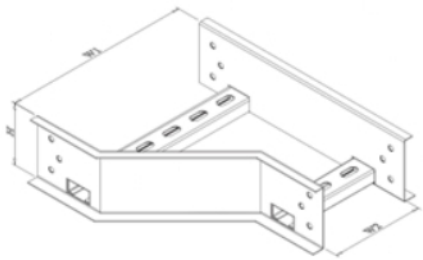

LRL- Reducer Left
Finish/LRL/Width/ Height/ Thickness

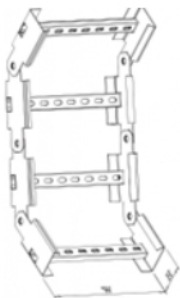

LVAB- Vertical Adjustable Bend
Finish/LVAB/Width/ Height/
Thickness

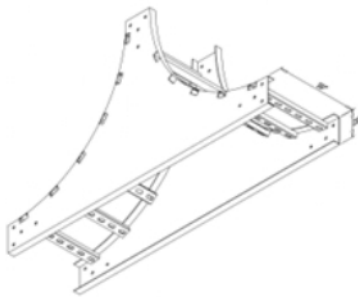

LV9T- Vertical 90° Tee
Finish/LV9T/Width/ Height/ Thickness

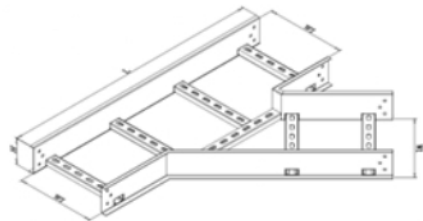

LY4B- WYE 45° Branche
Finish/LY4B/Width/ Height/ Thickness



CABLE LADDER FITTINGS

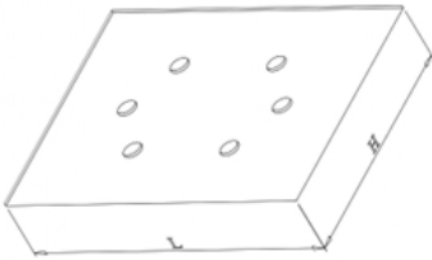

LA-101- Straight Connector

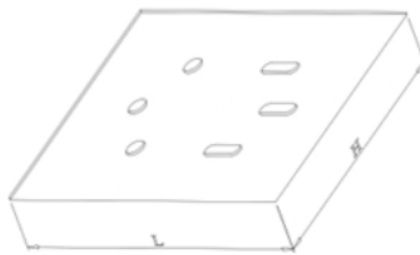

LA-102- Expansion Connector

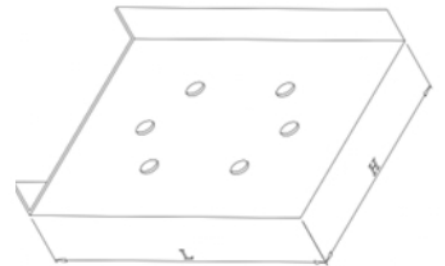

LA-103- Wrapover Connector



LA-104- Vertical Adjustable Connector

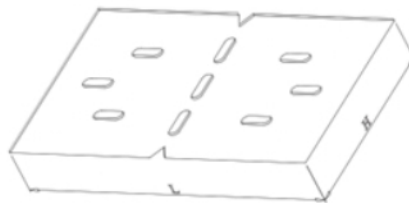

LA-105- Horizontal Adjustable Connector

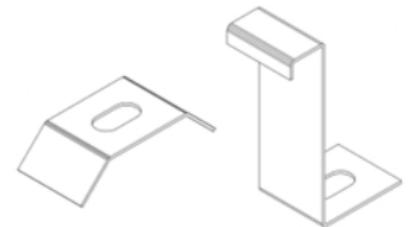

LA-110 & LA-111 Hold Down Clamp & Bracket

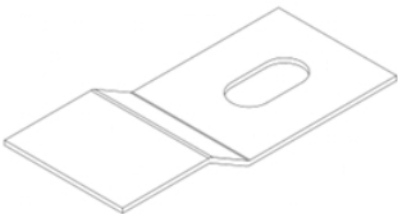

LA-107- Expansion Guide

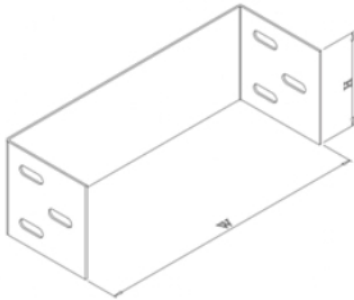

LA-108- End Plate

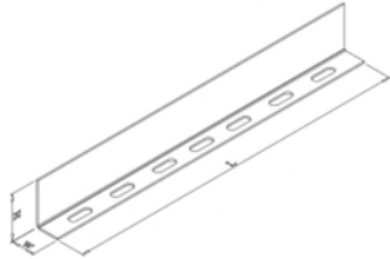

LA-109- Straight Divider

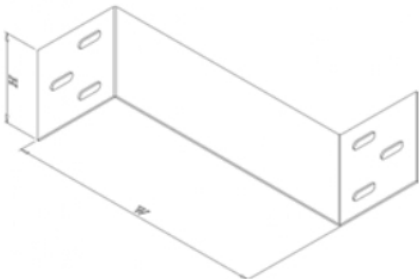

LA-106- Reducing Connector

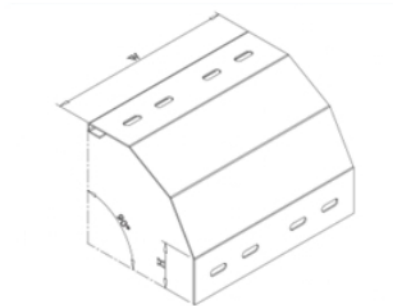

LA-112 Drop Out



LA-113 Earth Link

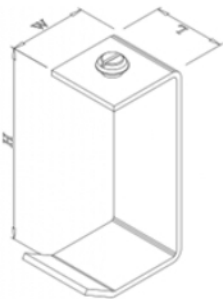

LA-114 Cover Clamp With Screw

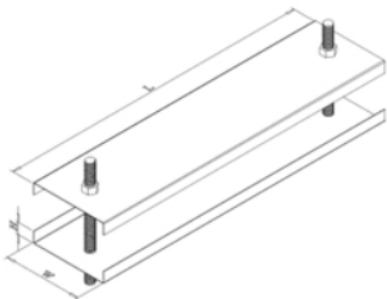

LA-115 Double Cover Clamp



CABLE TRAY & LADDER COVERS

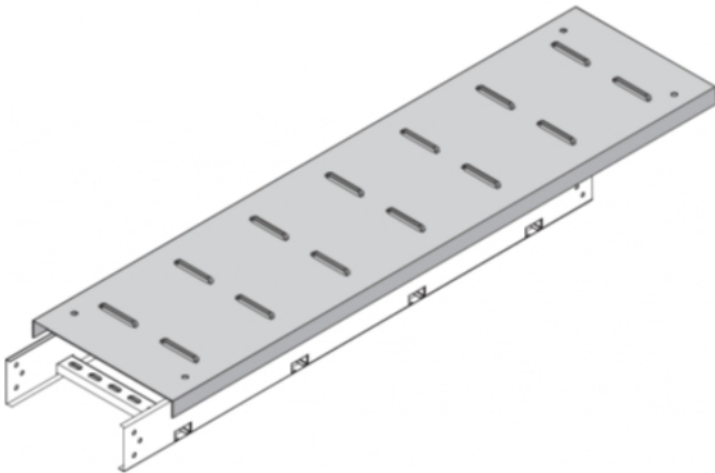
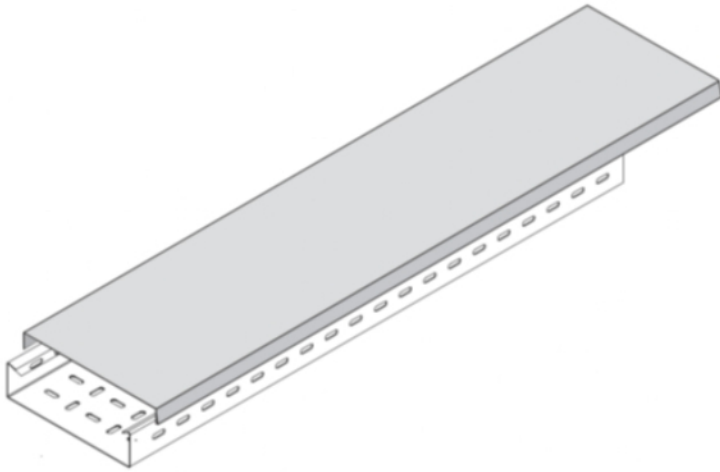



▶ ORDERING GUIDE

Cable Tray & Ladder Straight Cover - CC

GI	Material Finish
CC	Material Type
CP	Cover Type
300	Cover Width
15	Cover Height
1.5	Cover Thickness
3000	Cover Length

Cable Tray & Ladder Filling Cover - CC

GI	Material Finish
CC	Material Type
CP	Cover Type
TH9BC	Filling Type
300	Cover Width
15	Cover Height
1.5	Cover Thickness



ORDERING INFORMATION

Material Finish	Cover Type	Cover Width	Side Height	Material Thickness	Length
HG- Hot Dip Galvanized after fabrication (HDGAF) to BS ISO EN 1461 (BS 729)	CPE- Plain Edged Type	2 in - 50 mm	1 in - 25 mm	1.2 mm	2440 mm
GI- Pre-Galvanized steel (Mill Finish) to BS EN 10346:2009 (BS EN 10142 & BS 2989)	CP- Plain Type	3 in - 75 mm	2 in - 50 mm	1.5 mm	3000 mm
AL- Aluminium (Mill Finish)	CVE- Ventilated Edged Type	4 in - 100 mm	3 in - 75 mm	2.0 mm	
S6- Stainless Steel 316 (Mill Finish)	CV- Ventilated Type	6 in - 150 mm	4 in - 100 mm	2.5 mm	
S4- Stainless Steel 304 (Mill Finish)		9 in - 225 mm	6 in - 150 mm		
		12 in - 300 mm			
		18 in - 450 mm			
		24 in - 600 mm			
		30 in - 750 mm			
		36 in - 900 mm			

Finish	Reference	Width	Heigh	Thickness	Length
HG/GI/AL/S4/S6	CPE/CVE/CP/CV	50	15/25/50	1.2/1.5/2.0mm	2440/3000mm
HG/GI/AL/S4/S6	CPE/CVE/CP/CV	75	15/25/50	1.2/1.5/2.0mm	2440/3000mm
HG/GI/AL/S4/S6	CPE/CVE/CP/CV	100	15/25/50	1.2/1.5/2.0mm	2440/3000mm
HG/GI/AL/S4/S6	CPE/CVE/CP/CV	150	15/25/50	1.2/1.5/2.0mm	2440/3000mm
HG/GI/AL/S4/S6	CPE/CVE/CP/CV	225	15/25/50	1.2/1.5/2.0mm	2440/3000mm
HG/GI/AL/S4/S6	CPE/CVE/CP/CV	300	15/25/50	1.5/2.0mm	2440/3000mm
HG/GI/AL/S4/S6	CPE/CVE/CP/CV	450	15/25/50	1.5/2.0mm	2440/3000mm
HG/GI/AL/S4/S6	CPE/CVE/CP/CV	600	15/25/50	1.5/2.0mm	2440/3000mm
HG/GI/AL/S4/S6	CPE/CVE/CP/CV	750	15/25/50	1.5/2.0mm	2440/3000mm
HG/GI/AL/S4/S6	CPE/CVE/CP/CV	900	15/25/50	1.5/2.0mm	2440/3000mm



TRAY & LADDER COVER FITTINGS

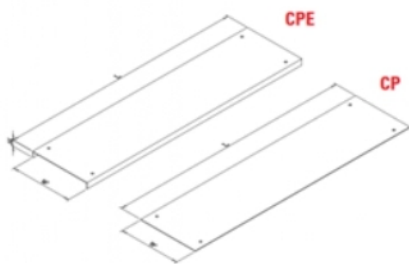

Plain Covers With Edge And Without Edge

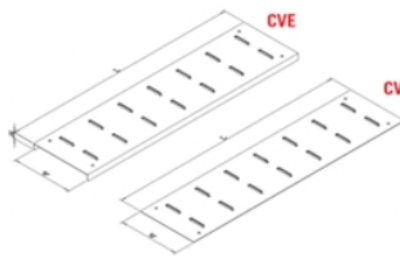

Ventilated Covers With Edge And Without Edge

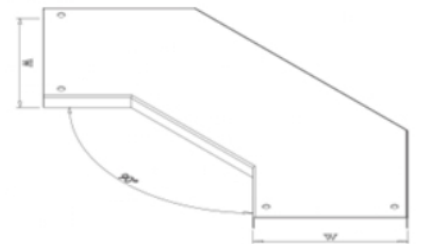

CH9B- Horizontal 90° Bend Cover
Finish/CH9B/Width/ Height/ Thickness

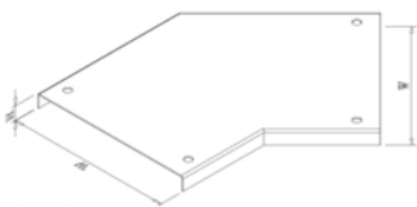

CH4B- Horizontal 45° Bend Cover
Finish/CH4B/Width/ Height/ Thickness

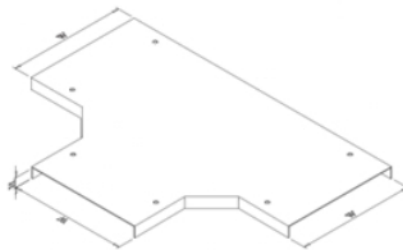

CHT- Horizontal Tee Cover
Finish/CHT/Width/ Height/ Thickness

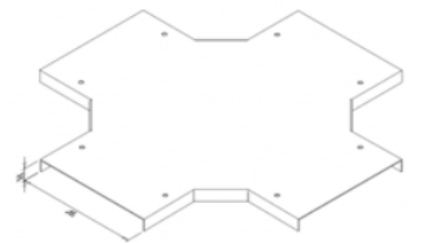

CHC- Horizontal Cross Cover
Finish/CHC/Width/ Height/ Thickness

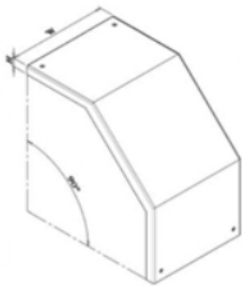

COR- Outside Riser Cover
Finish/COR/Width/ Height/ Thickness

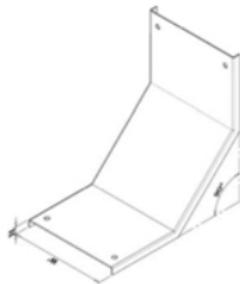

CIR- Insider Riser Cover
Finish/CIR/Width/ Height/ Thickness

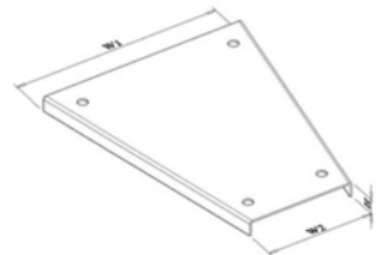

CRS- Reducer Straight Cover
Finish/CRS/Width/ Height/ Thickness

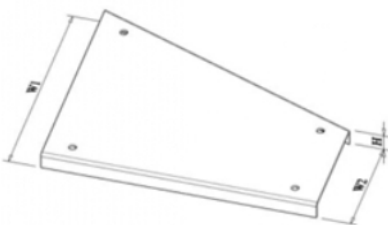

CRR- Reducer Right Cover
Finish/CRR/Width/ Height/ Thickness

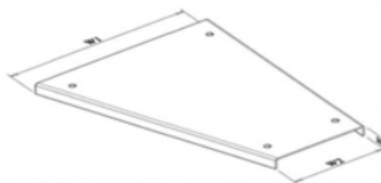

CRL- Reducer Left Cover
Finish/CRL/Width/ Height/ Thickness

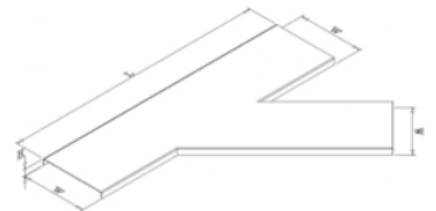

CY4B- WYE 45° Bend Cover
Finish/CY4B/Width/ Height/ Thickness



CABLE TRUNKING ASSEMBLY

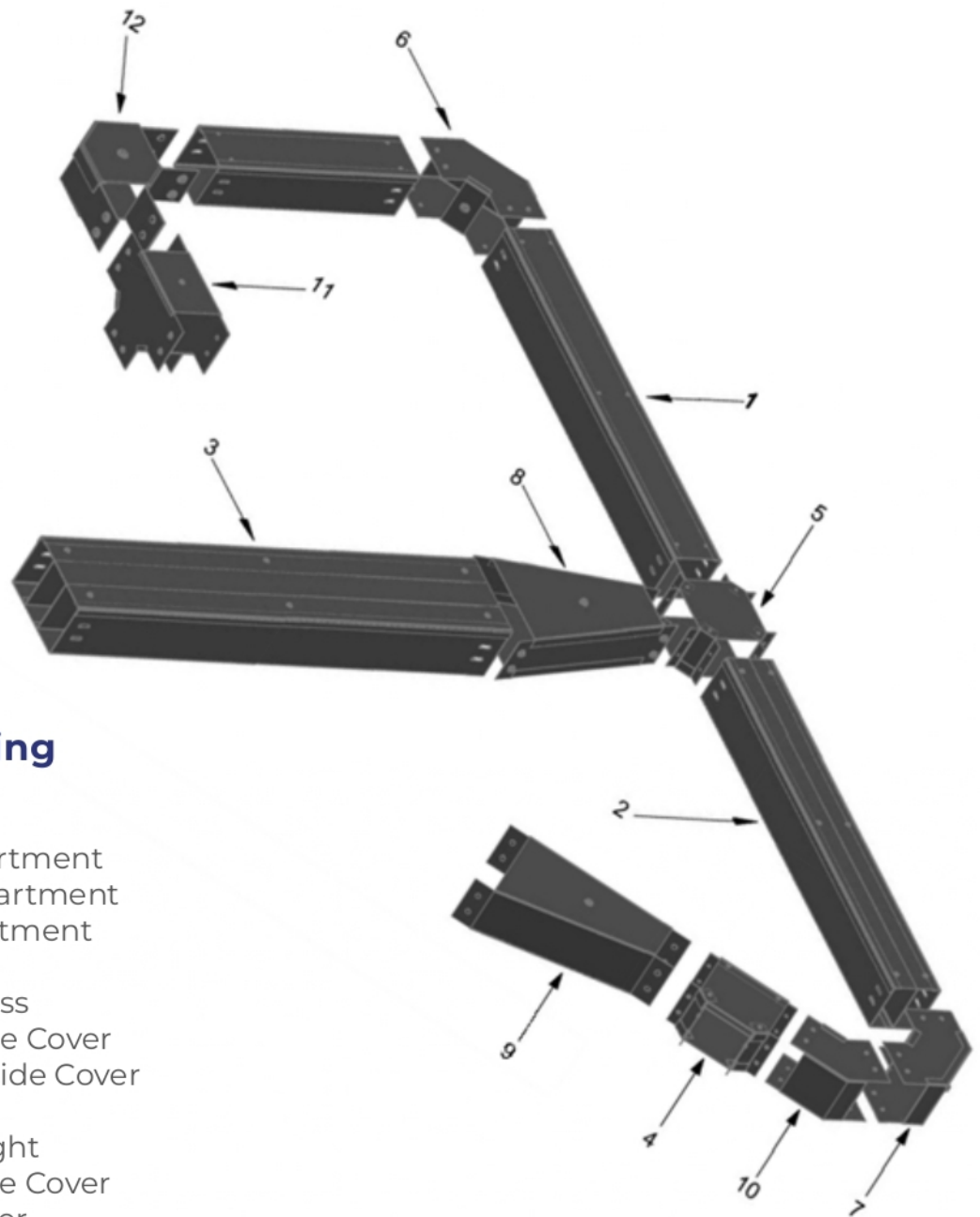

Cable Trunking Assembly

- Single Compartment
- Double Compartment
- Triple Compartment
- Horizontal Tee
- Horizontal Cross
- 90° Bend Inside Cover
- 90° Bend Outside Cover
- Bell Mouth
- Reducer Straight
- 45° Bend Inside Cover
- Tee Inside Cover
- 90° Bend Top Cover

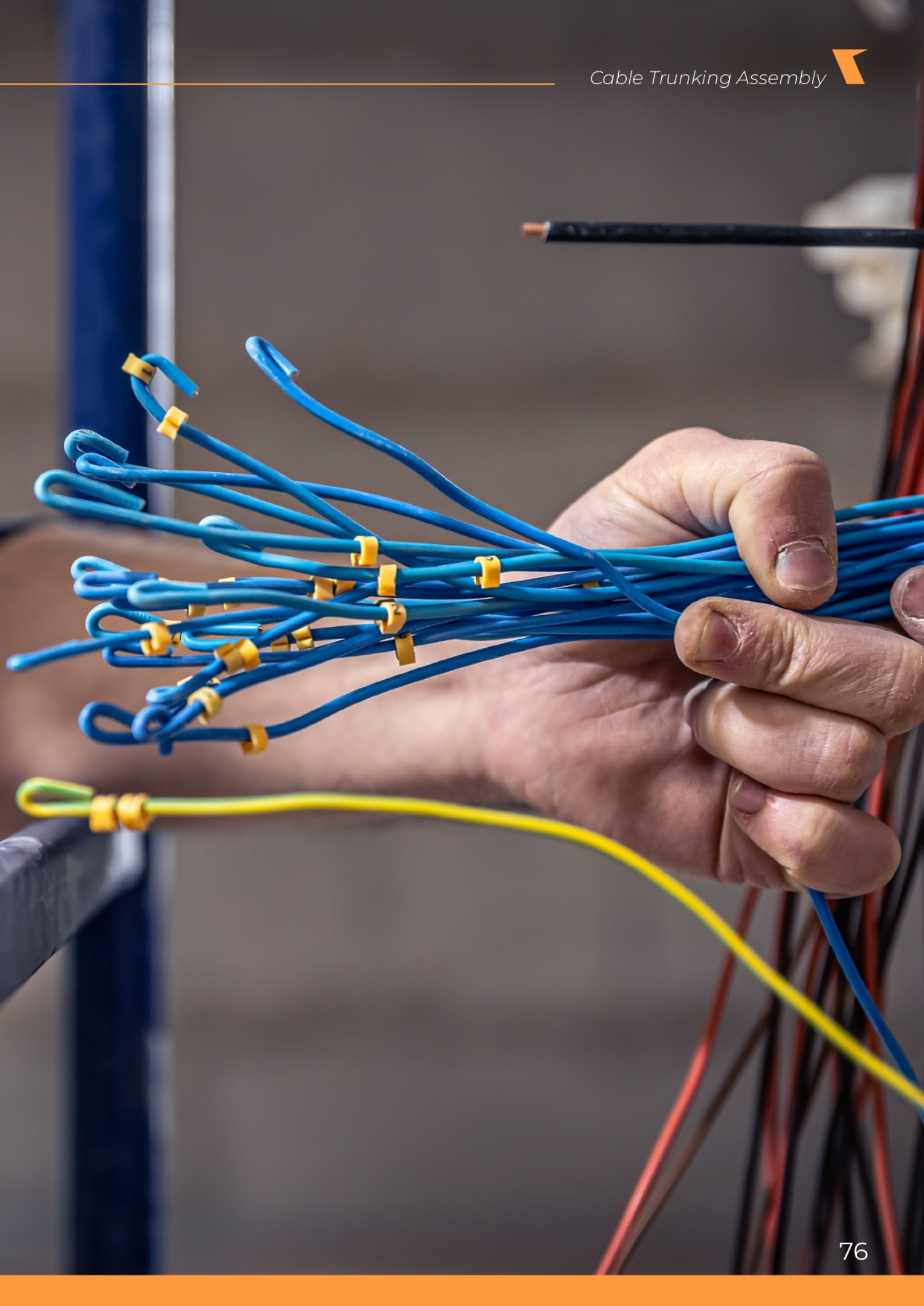

▶ ORDERING GUIDE

Cable Trunking Straight (Solid Type) - CK



Cable Trunking Filling (Solid Type) - CK





ORDERING INFORMATION



Material Finish	Tray Type	Tray Width	Side Height	Material Thickness	Length
HG- Hot Dip Galvanized after fabrication (HDGAF) to BS ISO EN 1461 (BS 729)	KS- Single Compartment	1 in - 25 mm	1 in - 25 mm	1.0 mm	2440 mm
GI- Pre-Galvanized steel (Mill Finish) to BS EN 10346:2009 (BS EN 10142 & BS 2989)	KD- Double Compartment	2 in - 50 mm	2 in - 50 mm	1.2 mm	3000 mm
AL- Aluminium (Mill Finish)	KT- Triple Compartment	3 in - 75 mm	3 in - 75 mm	1.5 mm	
S6- Stainless Steel 316 (Mill Finish)		4 in - 100 mm	4 in - 100 mm	2.0 mm	
S4- Stainless Steel 304 (Mill Finish)		6 in - 150 mm	6 in - 150 mm		

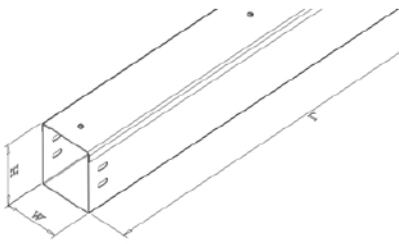

KS- Single Compartment

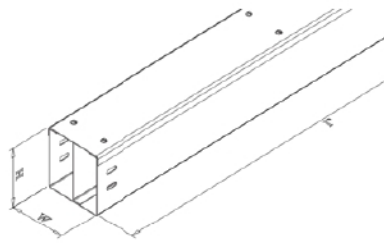

KD- Double Compartment

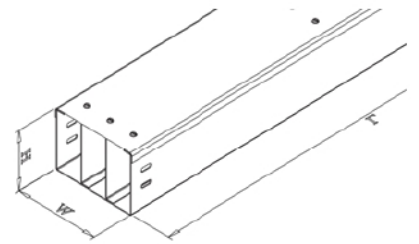

KT- Triple Compartment

Finish	Reference	Width	Heigh	Thickness	Length
HG/GI/AL/S4/S6	KS/KD/KT	50	25/50	1.2/1.5/2.0mm	2440/3000mm
HG/GI/AL/S4/S6	KS/KD/KT	75	25/50/75	1.2/1.5/2.0mm	2440/3000mm
HG/GI/AL/S4/S6	KS/KD/KT	100	25/50/75/100	1.2/1.5/2.0mm	2440/3000mm
HG/GI/AL/S4/S6	KS/KD/KT	150	50/75/100/150	1.2/1.5/2.0mm	2440/3000mm
HG/GI/AL/S4/S6	KS/KD/KT	200	50/75/100/150/200	1.2/1.5/2.0mm	2440/3000mm
HG/GI/AL/S4/S6	KS/KD/KT	250	75/100/150/200/250	1.2/1.5/2.0mm	2440/3000mm
HG/GI/AL/S4/S6	KS/KD/KT	300	75/100/150/200/250/300	1.2/1.5/2.0mm	2440/3000mm



CABLE TRUNKING FITTING

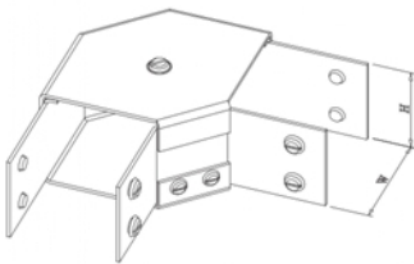

K9BT-90° Bend Top Cover

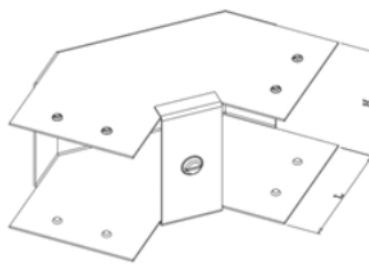

K9BI-90° Bend Inside Cover

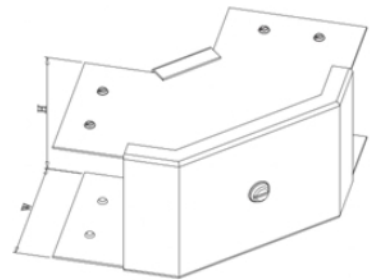

K9BO-90° Bend Outside Cover

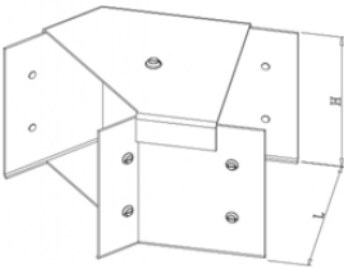

K4BT-45° Bend Top Cover

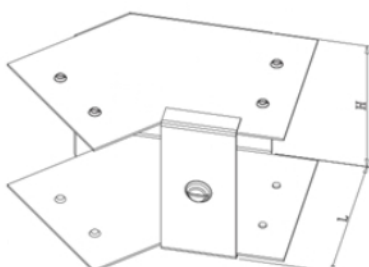

K4BI-45° Bend Inside Cover

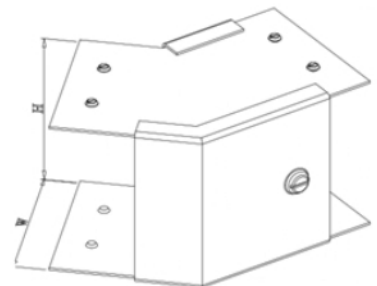

K4BO-45° Bend Outside Cover

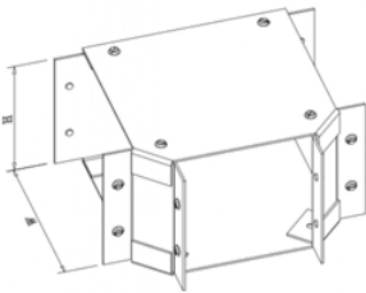

KTT-TEE Top Cover

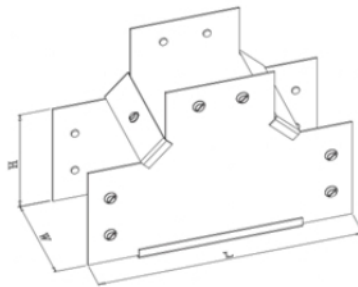

KTI-TEE Inside Cover

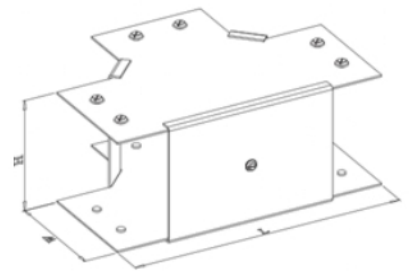

KTO-TEE Outside Cover

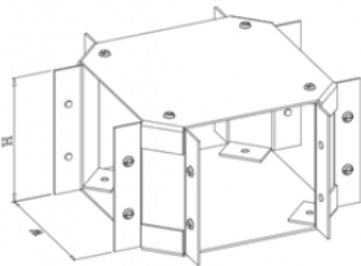

KCT- Cross Top Cover

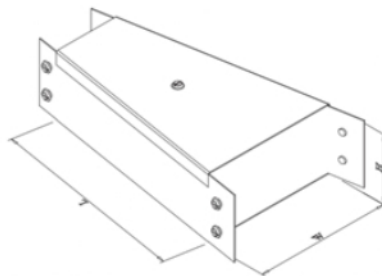

KRS- Reducer Straight

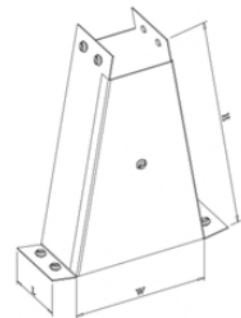

KBM- Bell Mouth



FITTINGS

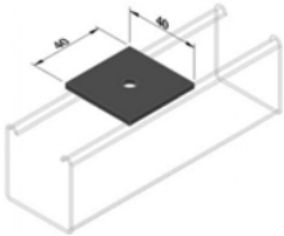

GC-101

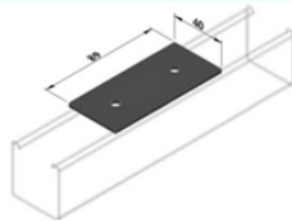

GC-102

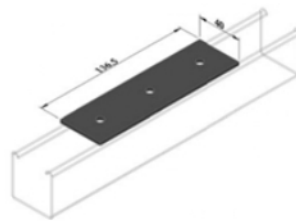

GC-103

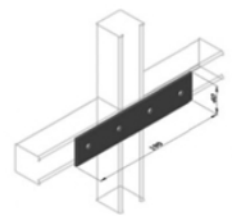

GC-104

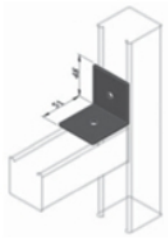

GC-105

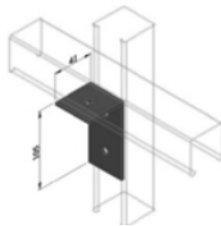

GC-106

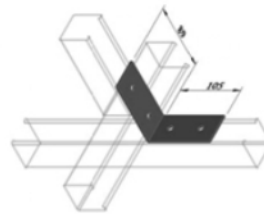

GC-107

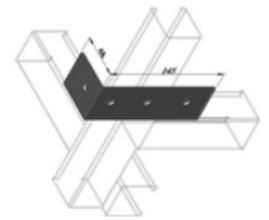

GC-108

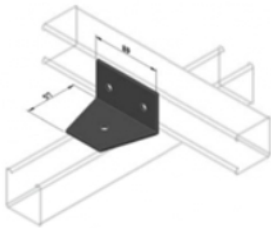

GC-109

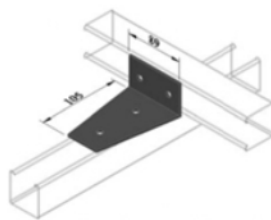

GC-110

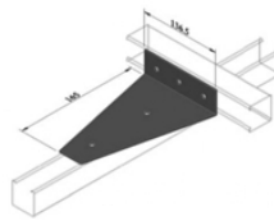

GC-111

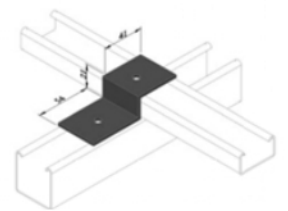

GC-112

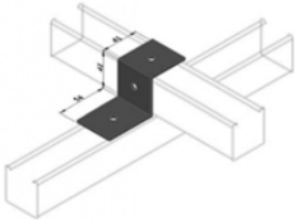

GC-113

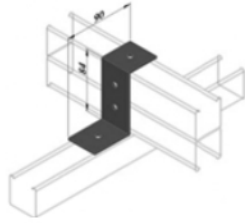

GC-114

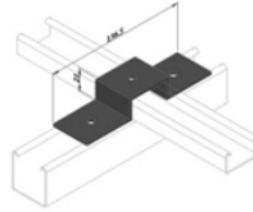

GC-115

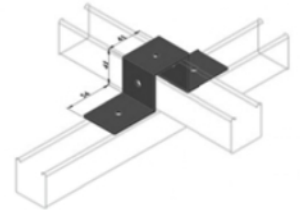

GC-116

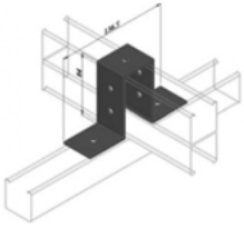

GC-117

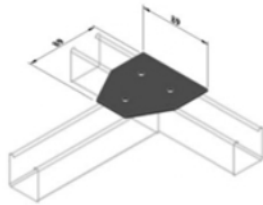

GC-118

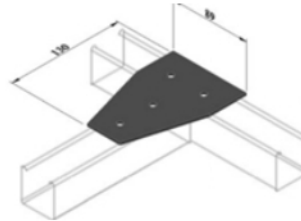

GC-119

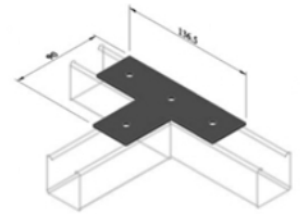

GC-120

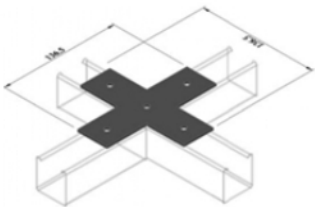

GC-121

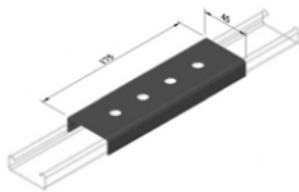

GC-122

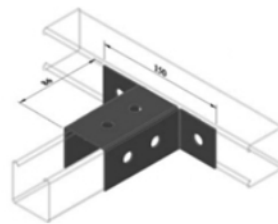

GC-123

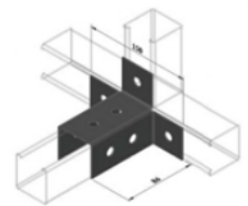

GC-124

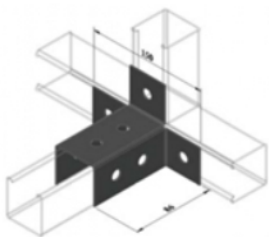

GC-125

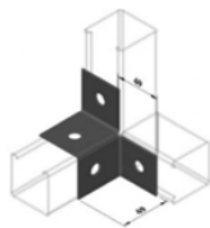

GC-126



GC-127

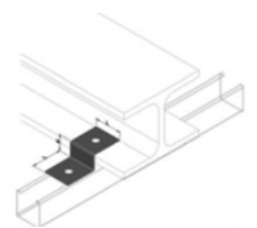

GC-128

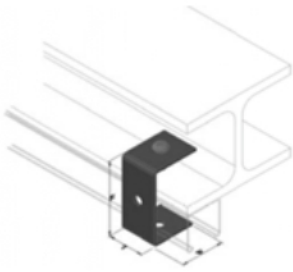

GC-129

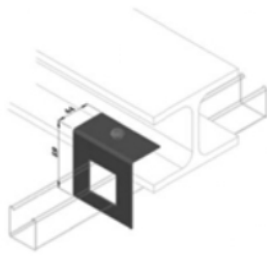

GC-130

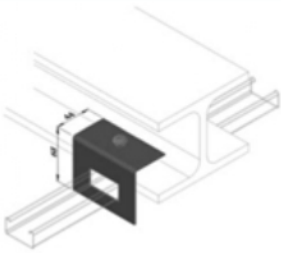

GC-131

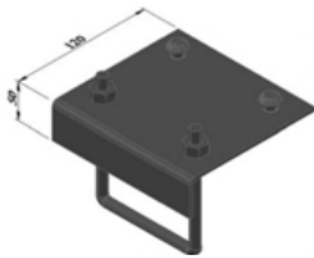

GC-132





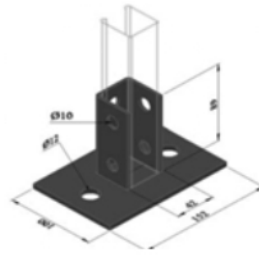

GC-201

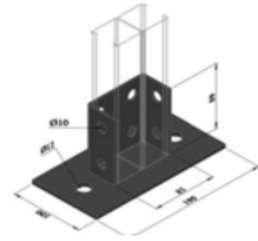

GC-202

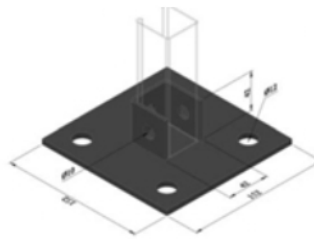

GC-205

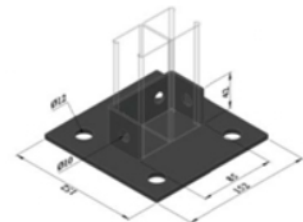

GC-206



BASE PLATES

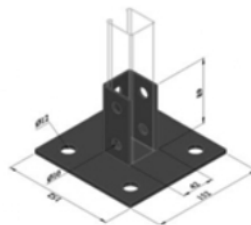

GC-203

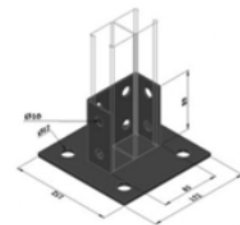

GC-204

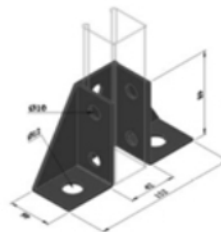

GC-207

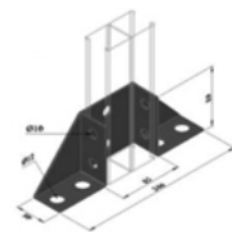

GC-208



CANTILEVER ARMS

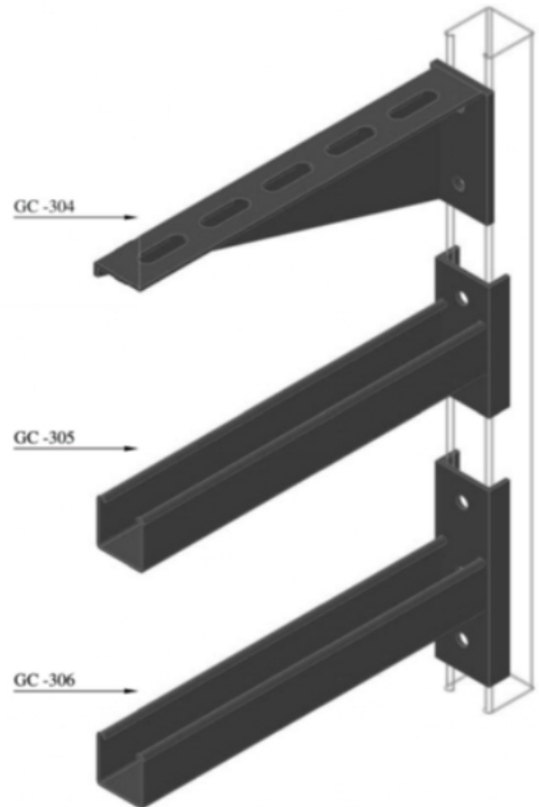
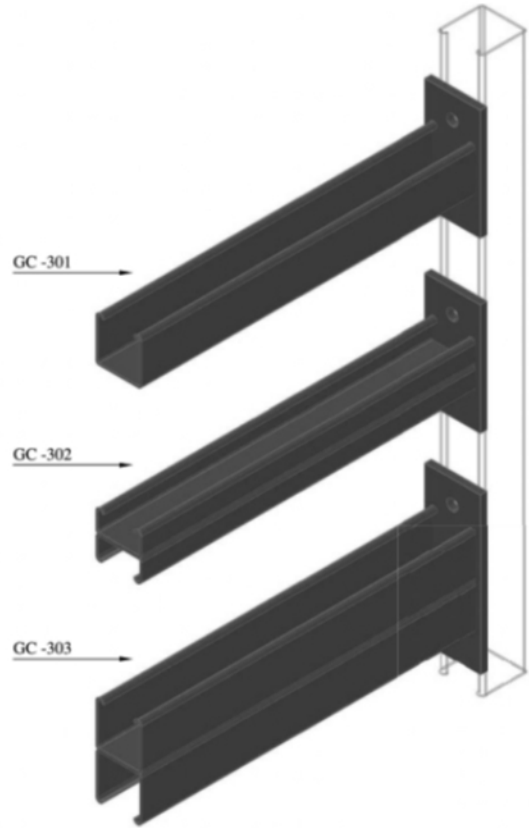



HARDWARE



F1- Hex Head Screw



F2- Roofing Head Bolt



F3- Pan Head Screw



F4- Cup Head Hex Bolt



F5- Hex Nut



F6- Square Nut



F7- Flange Hex Nut



F8- Flat Washer



F9- Shake Proof Washer



F10- Spring Washer



F11- Threaded Rod



F12- Anchor Bolt



F13- Channel Nut - Long Spring



F14- Channel Nut - Short Spring



F15- Channel Nut - Plain





POBox: 8485, Abu Dhabi, UAE
Tel: +971 2 5511188 | Fax: +971 2 55 10188
Email: galvaind@eim.ae

www.galvaccoat.ae
